

Bid Document



GUJARAT INFORMATICS LIMITED
Block No. 1, 8th Floor, Udyog Bhavan,
Sector-11, Gandhinagar 382 010
Phone No: 079 - 23256022
Fax No: 079 - 23238925

**RFP for Selection of Agency for Supply, Installation,
Commissioning & Maintenance of Hardware
Security Module for Department of Science &
Technology, Gandhinagar
(Tender No. HWT181017472)**

Pre-bid Meeting: 30.10.2017 at 1500 hours

Last Date of Submission of Bid: 09.11.2017 till 1500 hours

Last Date of Submission of Bid Processing Fees & EMD: 09.11.2017 till 1500 hours

Date of Opening of Technical Bid: 09.11.2017 on 1700 hours

Bid Processing Fee: Rs. 5900/- (Including G.S.T.)

DISCLAIMER

The information contained in this Request for Proposal (RFP) document or subsequently provided to Bidder(s), whether verbally or in documentary or any other form by or on behalf of the Department of Science & Technology, Government of Gujarat or any of their employees or consultants, is provided to Bidder(s) on the terms and conditions set out in this RFP and such other terms and conditions subject to which such information is provided.

The purpose of this RFP is to provide interested parties with information that may be useful to them in eliciting their financial offers (the "Proposal") pursuant to this RFP. This RFP includes statements, which reflect various assumptions and assessments arrived at by the TENDERER, in relation to the RFP. Such assumptions, assessments and statements do not purport to contain all the information that each Bidder may require. This RFP may not be appropriate for all persons, and it is not possible for the TENDERER, its employees or Consultants to consider the investment objectives, financial situation and particular needs of each party who reads or uses this RFP. The assumptions, assessments, statements and information contained in this RFP, may not be complete, accurate, adequate or correct. Each Bidder should, therefore, conduct its own surveys and analysis and should check the accuracy, adequacy, correctness, reliability and completeness of the assumptions, assessments, statements and information contained in this RFP and obtain independent advice from appropriate sources before filling up the RFP. Any deviation in the specification or proposed solutions will be deemed as incapability of the respective Agency and shall not be considered for final evaluation process.

Information provided in this document to the Bidder(s) is on a wide range of matters, some of which depends upon interpretation of law. The information given is not an exhaustive account of statutory requirements and should not be regarded as a complete or authoritative statement of law. The TENDERER accepts no responsibility for the accuracy or otherwise for any interpretation or opinion on law expressed herein.

TENDERER- its employees and advisors make no representation or warranty and shall have no liability to any person, including any Applicant or Bidder under any law, statute, rules or regulations or tort, principles of restitution or unjust enrichment or otherwise for any loss, damages, cost or expense which may arise from or be incurred or suffered on account of anything contained in this RFP or otherwise, including the accuracy, adequacy, correctness, completeness, delay or reliability of the RFP and any assessment, assumption, statement or information contained therein or deemed to form part of this RFP or arising in any way during the Bidding process.

Table of Contents

SECTION – 1	1
1.1 Information Regarding RFP	1
1.2 Instruction to the bidders for online bid submission	1
1.3 Abbreviations.....	3
1.4 DEFINITIONS	3
SECTION – 2	7
2.1. Introduction	7
2.2. Scope of Work.....	7
A. Supply, Installation, Testing and Commissioning of Network based Hardware Security Module (HSM) At GSDC	8
SECTION – 3	13
SECTION – 4	15
4.1 Technical Specifications	15
SECTION – 5	18
5.1.1. Service Level and Penalty Clause	18
5.2. Payments Terms	19
SECTION - 6.....	22
6.1. General Instruction to Bidders	22
6.2. Cost of Bidding	22
6.3. Bidding Document	22
6.4. Clarification on Bidding Document.....	22
6.5. Amendment of Bidding Documents	23
6.6. Language of Bid	23
6.7. Bid Security/ Earnest Money Deposit (EMD)	23
6.8. Late Bids	24
6.9. Section Comprising the Bids	24
6.10. Bid Opening	25
6.11. Bid Validity	25
6.12. Contacting the Tenderer	25
6.13. Rejection of Bids	26
6.14. Bid Evaluation Process.....	26
6.15. Award of Contract	26
6.16. Notification of Award & Signing of Contract	26
6.17. Force Majeure	27
6.18. Contract Obligations.....	28

6.19.	Amendment to the Agreement	28
6.20.	Representations and Warranties	28
6.21.	Resolution of Disputes.....	30
6.22.	Books & Records.....	30
6.23.	Warranty Terms	30
6.24.	Performance Guarantee	31
6.25.	Termination Clause	31
6.26.	Indemnification	32
6.27.	Limitation of Liability.....	32
6.28.	Confidentiality	32
6.29.	Service Terms	33
6.30.	Warranty Support	33
6.31.	Fraudulent and Corrupt Practices.....	34
6.32.	Acceptance Tests	34
6.33.	Copyright and Intellectual Property Rights.....	35
6.34.	Approvals/Clearances.....	35
6.35.	License Management.....	35
SECTION - 7	37
SECTION - 8	38

SECTION - 1
KEY INFORMATION
&
INSTRUCTIONS

SECTION – 1

1.1 Information Regarding RFP

Proposal in the form of BID is requested for the item(s) in complete accordance with the documents/attachments as per following guidelines.

- i. Bidder shall upload their bids on <https://www.gil.nprocure.com>
- ii. The Bid Security and non-refundable bid processing fees in a separate sealed envelope super scribed with the bid document number to GIL office.
- iii. Bids complete in all respects should be uploaded on or before the BID DUE DATE.
- iv. Technical Bids will be opened in the presence of Bidders' or their representatives who choose to attend on the specified date and time.
- v. In the event of the date specified for receipt and opening of bid being declared as a holiday for GIL office, the due date for submission of bids and opening of bids will be the next working day at the appointed time.
- vi. Services offered should be strictly as per requirements mentioned in this Bid document.
- vii. Please spell out any unavoidable deviations, Clause/ Article-wise in your bid under the heading Deviations.
- viii. Once quoted, the bidder shall not make any subsequent price changes, whether resulting or arising out of any technical / commercial clarifications sought regarding the bid, even if any deviation or exclusion may be specifically stated in the bid. Such price changes shall render the bid liable for rejection.
- ix. The bid submitted should be valid for a period of 180 days.
- x. The duration of the Contract period for this activity will be of 05 years.
- xi. In addition to this RFP, the following sections attached are part of Bid Documents.

Section	Details
Section – 1	Key Information & Instructions
Section – 2	Introduction and Scope of Work
Section – 3	Eligibility Criteria
Section – 4	Technical Specification
Section – 5	Service Level Agreement, Penalties & Payment Terms
Section – 6	Instruction to Bidders
Section – 7	Price Bid
Section – 8	Annexures & Formats

1.2 Instruction to the bidders for online bid submission

- i. Tender documents are available only in electronic format which Bidders can download free of cost from the website www.gil.gujarat.gov.in and <https://gil.nprocure.com>
- ii. The bids have been invited through e-tendering route, i.e. the eligibility criteria, technical and financial stages shall be submitted online on the website <https://gil.nprocure.com>
- iii. Bidders who wish to participate in this bid, will have to register on <https://gil.nprocure.com>, such bidders will have to procure Digital Certificate as per Information Technology Act 2000 using which they can Sign their electronic bids. Bidders can procure the same from (n) code solutions – a division of GNFC Ltd., or any other licensed by Controller of Certifying Authority, Govt. of India. Bidders who already have a valid Digital Certificate need not procure a new Digital Certificate.
- iv. Interested and eligible Bidders are required to upload the eligibility related document in eligibility bid section, Technical related document in Technical bid section & Commercial Bid in Commercial bid

section. The Bids should be accompanied by a bid security & bid processing fees (non-refundable) as specified in this Bid Document. The Technical & Commercial Bid must be uploaded to <https://gil.nprocure.com> & the Bid Security and bid processing fees must be delivered to the office of Gujarat Informatics Ltd on or before the last date and time of submission of the bid.

- v. The eligibility section and the Bid Security & bid processing fees section will be opened on the specified date & time in presence of the Bidders or their authorized representative who choose to attend. In the event of the date specified for bid receipt and opening being declared as a holiday for the office of Gujarat Informatics Ltd the due date for submission and opening of bids will be the following working day at the scheduled times.
- vi. In case of any clarifications required, please contact DGM (Tech), GIL in writing 5 days before the Pre-Bid meeting date.

Important Dates

Request for proposal (RFP) for Selection of Agency for Supply, Installation, Commissioning & Maintenance of Hardware Security Module for Department of Science & Technology, Gandhinagar		
	Contract Period	5 years
	Pre-Bid Meeting	30.10.2017 at 1500 hours Gujarat Informatics Limited, Block No.1, 8 th Floor, Udyog Bhawan, Gandhinagar-382010
	Bid Due date	09.11.2017 up to 1500 hours
	Date of Opening of Un-priced bid	09.11.2017 at 1700 hours
	Date & Time of opening of Technical & Commercial stage	Will be intimated to the qualified bidders at a later date.
	Venue of opening of Technical & Commercial Bid/s	Gujarat Informatics Limited, Block No.1, 8 th Floor, Udyog Bhawan, Gandhinagar-382010
	Bid Processing Fees (Non-refundable)	Rs. 5900 (Including G.S.T.) (Rupees Five Thousand Nine Hundred Only)
	Bid security (EMD)	Rs. 2,00,000 (Rupees Two Lakh Only)
	GIL Contact person	DGM (Technical)

DGM (Tech.)

Gujarat Informatics Limited,
8th Floor, Block No.1, Udyog Bhawan,
Gandhinagar 382010,
Phone : 079 - 232 59239
E-mail: viveku@gujarat.gov.in

1.3 Abbreviations

ASA	Authentication Service Agency
AUA	Authentication User Agency
CIDR	Central Identities Data Repository
DST	Department of Science & Technology
GIL	Gujarat Informatics Limited
GoG	Government of Gujarat
GSWAN	Gujarat State Wide Area Network
HSM	Hardware Security Module
QP	Quarterly Payment
RFP	Request for Proposal
SLA	Service Level Agreement
STQC	Standardization Testing and Quality Certification, Govt. of India
UIDAI	Unique Identification Authority of India

1.4 DEFINITIONS

In this document, the following terms shall have following respective meanings:

1. "Acceptance Test Document" means a document, which defines procedures for testing the installed and commissioned product and services against requirements laid down in the Agreement.
2. "Agreement" means the Service Level Agreement to be signed between the successful bidder and TENDERER including all attachments, appendices, all documents incorporated by reference thereto together with any subsequent modifications/changes/corrigendum's, the RFP, the bid offer, the acceptance and all related correspondences, clarifications, presentations.
3. "Authorized Representative/ Agency" shall mean any person/ agency authorized by either of the parties.
4. "Bidder" means any agency who fulfils the requirement laid in the RFP documents and is possess the required expertise and experience as per the RFP document. The word Bidder when used in the pre-award period shall be synonymous with Bidder, and when used after award of the Contract shall mean the successful Bidder with whom TENDERER signs the Service Level Agreement for executing the project.
5. "Contract" is used synonymously with Agreement.
6. "Corrupt Practice" means the offering, giving, receiving or soliciting of anything of value or influence the action of a public official in the process of Contract execution.
7. "Default Notice" means the written notice of Default of the Agreement issued by one Party to the other in terms hereof.
8. "Fraudulent Practice" means a misrepresentation of facts to influence a procurement process or the execution of a Contract and includes collusive practice among Bidders (prior to or after Bid submission) designed to establish Bid prices at artificial non- competitive levels and to deprive TENDERER of the benefits of free and open competition.
9. "Final Acceptance Test (FAT)" means the acceptance testing of all the commissioned project component at all specified locations.

10. "Go Live Date" means the date on which the FAT of all the project components as per the Work order has been successfully completed and accepted by the TENDERER.
11. "Good Industry Practice" means the exercise of that degree of skill, diligence and prudence which would reasonably and ordinarily be expected from a reasonably skilled and experienced Operator engaged in the same type of undertaking under the same or similar circumstances.
12. "Implementation Period" shall mean the period from the date of signing of the Agreement and up to the issuance of Final Acceptance Certificate.
13. "Law" shall mean any act, notification, by-law, rules and regulations, directive, ordinance, order or instruction having the force of law enacted or issued by the Central Government and/ or the Government of Gujarat or any other Government or regulatory authority or political subdivision of government agency.
14. "LoI" means Letter of Intent, which constitutes the intention of the TENDERER to place the Purchase Order with the successful bidder.
15. "Operator" means the entity/company providing the services / executing the project under the Agreement and is used synonymous with Bidder/Successful Bidder.
16. "O&M Period" means period of 05 years starting with the successful, installation and commissioning and FAT of the project components. The date of start of O&M shall start from the (Go Live) date i.e. from the date of successful FAT of the equipment at the site location as per the work Order.
17. "OEM" Shall stand for Original Equipment manufacturer
18. "Period of Agreement" means 05 years' period starting with the commissioning of all Hardware and software ordered as per the Scope of work for the Project.
19. Request for Proposal", means the detailed notification seeking a set of solution(s), services(s), materials and/or any combination of them.
20. "Requirements" shall mean and include schedules, details, description, statement of technical data, performance characteristics, standards (Indian as well as International) as applicable and specified in the Agreement.
21. "Site" means the location(s) for which the Contract will be signed and where the service shall be provided as per agreement.
22. "Service" means provision of Contracted service viz., operation, maintenance and associated services for the Project.
23. "Service Down Time" (SDT) means the time period when specified services/network segments with specified technical and operational requirements as mentioned in this document are not available to TENDERER. The services shall be operational on all days of a year and 24- hours/ day with in the uptime specified in the Service Level Agreement (SLA). The services shall be considered as operational when all Centres at all tiers/ levels are working, providing all/ specified services as mentioned in full capacity at all locations in the network.
24. "TENDERER" here shall mean "Department of Science & Technology, Government of Gujarat".
25. "Termination Notice" means the written notice of termination of the Agreement issued by one Party to the other in terms hereof.
26. "Third Party Agency" means any agency, if/as appointed by TENDERER for monitoring the Project during commissioning and operation.
27. "Unplanned downtime" means an instance other than the planned down time in which ordered services are not available to TENDERER.
28. "Uptime" means the time period when specified services with specified technical and service standards as mentioned in in the RFP are available to TENDERER and its user organizations. The uptime will be calculated as follows:

“Total time in a quarter (in minutes) less total Service Down time (in minutes) in the quarter”

29. “User Acceptance Test (UAT)” means the User Acceptance Testing of the ordered product and services on completion of installation and commissioning as per the requirement.
30. "% Uptime" means ratio of 'up time' (in minutes) in a quarter to Total time in the quarter (in minutes) multiplied by 100.
31. “Work order” shall mean a formal order issued by TENDERER to the successful bidder covering delivery timelines, SLA and other terms and conditions.

SECTION - 2
INTRODUCTION
&
SCOPE OF WORK

SECTION – 2

Gujarat Informatics Limited (herein after referred to as GIL), on behalf of Department of Science & Technology (DST), Gandhinagar (herein after referred to as the TENDERER) invites bids from eligible bidders for Supply, Installation, Commissioning & Maintenance of Hardware Security Module.

2.1. Introduction

Aadhaar is a strategic policy tool for social and financial inclusion, public sector delivery reforms, managing fiscal budgets, increase convenience and promote hassle-free people-centric governance. Aadhaar can be used as a permanent Financial Address and facilitates financial inclusion of the underprivileged and weaker sections of the society and is therefore a tool of distributive justice and equality. The Aadhaar identity platform is one of the key pillars of the 'Digital India', wherein every resident of the country is provided with a unique identity. The Aadhaar program has already achieved several milestones and is by far the largest biometrics based identification system in the world.

Aadhaar number is a 12-digit random number issued by the UIDAI ("Authority") to the residents of India after satisfying the verification process laid down by the Authority. Any individual, irrespective of age and gender, who is a resident of India, may voluntarily enroll to obtain Aadhaar number. Person willing to enroll must provide minimal demographic and biometric information during the enrolment process which is totally free of cost. Individual needs to enroll for Aadhaar only once and after de-duplication only one Aadhaar shall be generated, as the uniqueness is achieved through the process of demographic and biometric de-duplication.

Aadhaar Authentication means the process by which the Aadhaar number along with the demographic information or biometric information of a Aadhaar number holder is submitted to the Central Identities Data Repository (CIDR) for its verification and such repository verifies the correctness, or the lack thereof, based on the information available with it.

To enhance the security of AADHAR authentication eco-system, under regulations 14(n) and 19 (0) of Aadhaar authentication regulations 2016, it is desirable to use HSM for digital signing of Auth XML and decryption of e-KYC data. Hence, to comply with the guidelines of UIDAI and Aadhaar act 2016, DST intends to deploy network based Hardware Security Modules (HSM) at its GSDC site to encrypt and digitally sign the request response packets. All the communication between ASA and CIDR are planned to be in a secure mode using encryption technologies, i.e., Digital Signing (integrity) and Encryption (Confidentiality). The data packets will be digital signed and encrypted while sending to CIDR and vice versa. Digital signing and encryption involves Keys which are the core part of the process and there should be proper measures taken to secure those keys so that no compromise happens.

2.2. Scope of Work

Selected bidder shall be responsible for supply, install, commission and O&M of supplied Hardware Security Module with all necessary peripherals, software, etc., to act as a trust anchor for secure key management which involves secure generation of Keys, Secure usage etc.

To comply with the guidelines of UIDAI HSM for the applications communicating with the network to CIDR, keys once generated on-board on an HSM should never travel outside the HSM box/appliance in any form.

Scope of Work is as per following:

A. Supply, Installation, Testing and Commissioning of Network based Hardware Security Module (HSM) At GSDC

Successful bidder is required to propose overall solution (not limited to) comprising of Network based HSM Device, other required hardware for installation, software, etc., with required license valid perpetual for life to fulfill the requirement, for the solution to work as per guidelines of UIDAI.

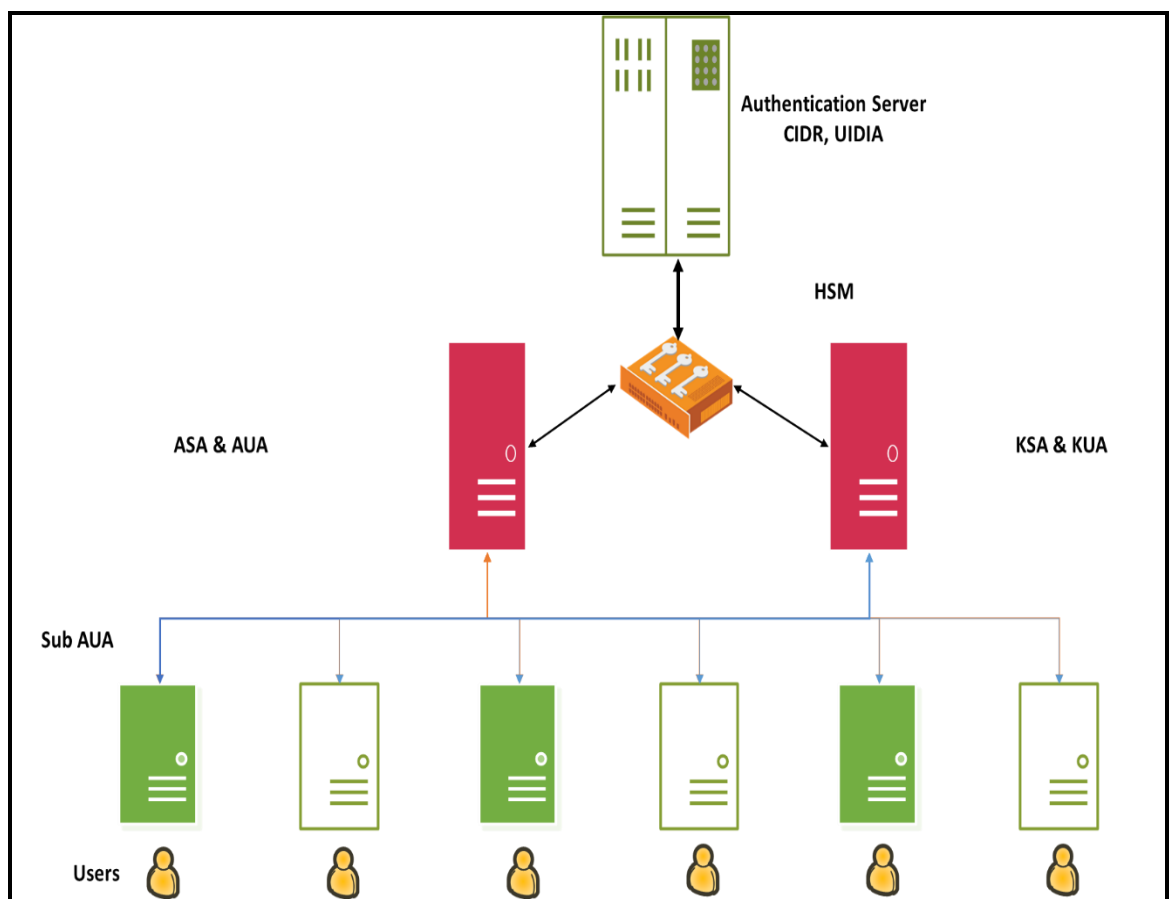

[Proposed schematic Diagram]

A. Supply, Installation, Commissioning & Testing

- i.) Bidder is required to supply, install, configure, integrate, test and commission the required Hardware (inclusive of all active and Passive components and sub components, Licenses, etc.) as per the technical and functional specification mentioned in the RFP document to successfully run the services

- ii.) The license procured by the bidder should be in the name of Department of Science and Technology, Government of Gujarat, valid perpetual for life.
- iii.) The bidder shall provide necessary APIs, configure the device, assist in modification of application and integrate the proposed solution with the existing set-up to provide services to the departments.
- iv.) The Bidder should ensure that if any additional component(s) required for overall solution to comply with the SLA levels, then in such case it should be the responsibility of the bidder to provide the same as a part of the entire solution.
- v.) The selected bidder is required to submit the certification from the OEM of the proposed solution confirming successful implementation, testing, commissioning and satisfactory deployment of the proposed solution based on the industry best practices as a part of FAT.
- vi.) The TENDERER or its authorized representative will conduct the Final Acceptance Test (FAT). FAT shall be considered completed successfully upon completion of all the required activities like Supply, Installation, Testing, Commissioning of the proposed solution as per the RFP/Contract agreement. FAT includes execution of test cases and verifying the expected results by The TENDERER or its representatives. The components and its performance will also be validated against the minimum specifications and requirements mentioned in the RFP / Agreement.
- vii.) The Bidder shall ensure that the products quoted should not be declared “End of Production” for next 2 years and “End of support” for the next 5 years by the OEM from the date of bid submission. However, if OEM declares any equipment as end of support for any reasons, then in that case, OEM should replace that equipment with better or equivalent products without any cost to the TENDERER. OEM also must submit on their letter head, complete details on the support available for the equipment, their end of support dates and replacement model, if any.
- viii.) The support including spares, patch updates, for the quoted products shall be available for the entire period of the Project without any additional cost.
- ix.) The bidder is required to provide OEM warranty & back to back OEM support (24 x 7 x 365 days) for the period of 05 years from the date of successful completion of FAT. The entire deployed solution should be covered under the back to back OEM warranty till successful completion of FAT.

B. Manpower

S/N	Description	Qty	Roles & Responsibility
1.	Support Executive: <ul style="list-style-type: none"> • B.E(EC/IT/Comp)/MCA/MSc.IT • 2 years of Experience in Java • Ability to perform the functioning/working of HSM 	1	<ul style="list-style-type: none"> • Ensuring the SLA and smooth functioning of HSM. • Assist TENDERER in application development / upgradation related to UIDAI • Perform the necessary upgrades in the API to ensure smooth functioning of UIDAI application in relation to HSM • Co-ordination with OEM, for any issues related to the device/UIDAI Application. • Any other work related to UIDAI Project of Government of Gujarat

Note: The TENDERER shall pay Rs. 40,000/Month for the Support Executive as a part of Quarterly Payment.

c. Operations & Maintenance Component

- i) Bidder shall be responsible for operation and maintenance of the supplied HSM solution as mentioned in the RFP/Agreement for the duration of the Contract.
- ii) During the O&M period, selected bidder shall be responsible for the following indicative (but not limited to) list of activities:
 - a. The bidder should ensure that any vulnerability or security advisory, as notified by the AUTHORITY or OEM should be fixed/complied as per SLA. The Bidder should regularly keep track of such notifications, and intimate concerned authority at GSDC and the TENDERER immediately.
 - b. Call log in help desk
 - c. The solution should be discovered in the existing CA NMS tool of GSDC.
 - d. The bidder needs to prepare checklist which is to be used for the smooth Operations of the solution as mentioned in the RFP/Agreement.
 - e. Bidder must ensure that the solution to be deployed does not disrupt the GSDC operations and affect other GSDC infrastructure in terms of performance and security.
 - f. API/application modification, any modifications required in the solution for adhering to the guidelines of UIDAI.

D. Key Deliverables

The bidder needs to provide following deliverables in accordance with the Implementation Timelines-

S/N	Deliverables	Activity
1.	Kick-off meeting	<ul style="list-style-type: none"> • Project Plan
2.	Delivery of Components	<ul style="list-style-type: none"> • Required Hardware (inclusive of all active and Passive components and sub components. Licenses, etc.) as per the technical and functional specification mentioned in the RFP/Agreement • Software License Documents • Hardware Warranty Certificate
3.	Installation & Commissioning	<ul style="list-style-type: none"> • Installation & Commissioning Report • Network Architecture documents • GUI design (screen design, navigation, etc.) • Completion of UAT and closure of observations • Application deployment and configuration • Integration, Testing Report • Test cases & SOPs for the solution
4.	FAT	<ul style="list-style-type: none"> • Successful deployment of required Hardware (inclusive of all active and Passive components and sub components. Licenses, etc.) as per the technical and functional specification mentioned in the RFP / Agreement. • Execution of test cases as may be provided at the time of FAT. • Discovery in Monitoring Tool
5.	O&M	<ul style="list-style-type: none"> • Issues logging and resolution report • SLA reports

		<ul style="list-style-type: none">• Preventive Maintenance plan• Operations manual for all components
--	--	--

SECTION - 3
ELIGIBILITY CRITERIA

SECTION – 3

S/N	Pre-Qualification Criteria	Attachments
1.	Bidder should be System Integrator / IT Company registered under Indian Companies Act 1956/2013, registered with the Service/sales Tax Authorities.	Certificates of incorporation & Self-Declaration Certificates
2.	The bidder should have annual average turnover of Rs. 5 Crore (Minimum) from the business of IT/ITES during the last three financial years as on 31.03.2017	The copies of Audited Annual Accounts/Balance Sheet along with Profit & Loss Account and CA Certified Statement for last three financial years shall be attached along with the bid
3.	Proposed solution should be deployed at minimum 02 projects in last 2 years	Work Orders / Client Certificates confirming year and area of activity
4.	The bidder must have one office in Gujarat. Please upload the copies of any two of the following: Property Tax Bill of last year / Electricity Bills of last one year / Telephone Bills of last one year / VAT Registration / CST Registration / Valid Lease Agreement.	In case, bidder does not have office in Gujarat, bidder should give undertaking to open office in Gujarat within 45 days from the date of purchase order.
5.	The bidder should be authorized by its OEM to quote in the bid. The bidder should have a back-to-back support agreement/arrangement for services including supply of spare parts etc. with the Original Equipment Manufacturer (OEMs).	Authorization certificate from OEM specific to this bid should be enclosed. Please upload the copy of Authorization on OEM letter head and signed by authorized signatory for the item(s) to be offered in this bid
6.	The bidder should not be under a declaration of ineligibility for corrupt and fraudulent practices issued by Government of Gujarat and / or black-listed by Any other state Government departments.	Self-Declaration
7.	Bidder or OEM should not be blacklisted by any Ministry of Government of India or by Government of any other State in India or by Government of Gujarat or any of the Government PSUs at the time of bidding.	Certificate / affidavit mentioning that the Bidder or OEM is not blacklisted by any Ministry of Government of India or by Government of any State in India or by Government of Gujarat or any of the Government PSUs. Self- Declaration Form must be submitted

Note:

- i. The Bidder must attach valid documents in support to their Technical and Financial capabilities/strength, as mentioned above. Without proper supporting documents, the Bid proposals are liable to be rejected.
- ii. All the proposed equipment should not be declared End-of-Support by the OEMs for next 7 years and should not be end of production for next one year from the date of bid submission.

SECTION - 4
TECHNICAL SPECIFICATIONS

SECTION – 4

4.1 Technical Specifications

Note:

All the specifications below are minimum specifications and higher specifications shall be used wherever necessary/required. Deviation on higher side shall only be considered and no extra weightage shall be awarded for such deviations.

S/N	Item Minimum Specifications	Compliance (Y/N)
1.	Should support Windows 2008 or higher, Linux, Solaris, HP UX, VMWARE, AIX	
2.	Should comply to standards FIPS 140-2 Level 3, ROHS	
3.	Key Length Supported (2048)	
4.	Public Key Algorithm RSA encrypt/decrypt, RSA sign/verify, ECC (Electric Curve cryptography)	
5.	Key Exchange Symmetric Algorithm: AES, DES, Triple DES	
6.	Support for Hash Message Digest HMAC, SHA1 SHA2 (224-512).	
7.	Support for various cryptographic algorithms: Asymmetric Key RSA (1024-8192 bits), Diffie-Hellman (1024 4096 bits), Elliptic Curve Cryptography DSA (1024-3072).	
8.	Random Number Generation –FIPS 140-2 approved	
9.	Support for PKCS#11, CAPI, OpenSSL, JCE/JCA.	
10.	All keys must be stored in FIPS certified hardware/device	
11.	If solution cannot backup CA keys using Smart Card/Crypto Token, bidder should provide appropriate mechanism to prepare backup device	
12.	Onboard key generation, signing inside the HSM.	
13.	Provision of delivery of new device on its failure without returning the failed one.	
14.	Support for multi factor authentication (Remote and Local)	
15.	HSM should provide the configurability such that HSM operations can be configured for mandatory manual interventions for all kind of operations & access to HSM. The following functionalities should be provided in HSM operations	

S/N	Item Minimum Specifications	Compliance (Y/N)
	i. Multiple Operators should be required to perform tasks / operations with traceability for each of the role.	
	ii. One operator should be able to perform multiple roles and each operation should be traced to operator's role	
	iii. HSM should require manual intervention for performing tasks / operations by inserting Token / Biometrics	
	iv. Audit Trails: Logs generated by HSM should provide the operators signatures / traces.	
16.	Support for minimum 1000 signatures per second at 2048 bits minimum, scalable up to 3000 signatures per second.	
17.	Support for Health checkup, Diagnostic commands such as PING/TRACERT/ NETSTAT for monitoring Ethernet connections and utilization statistics.	
18.	HSM should have the capabilities of 20 partitions in single appliance	
19.	HSM should support NMS integration.	
20.	Physical attack chassis Custom built chassis to guard against physical attack including the use of epoxy potting to shield internal circuitry and security labels to expose attempts to tamper with the device.	
21.	Monitoring Monitoring of environmental conditions including the integrity of the chassis, power supplies and temperature to detect potential attack	
22.	24x7 Telephonic/email/onsite support from OEM in India.	
23.	HSM Appliance shall be network (TCP / IP) based appliance.	
24.	The appliance shall support High Availability in Active/Passive cluster	
25.	The key generation speed of HSM's should be minimum 10 (Ten) key pair per second (RSA 2048 bits)	
26.	HSM OEM should have 24 x 7 support available directly from personnel from OEM in India	
27.	Key Updates - Key update between all HSM's can be automated without extra hardware for real time key availability	
28.	GUI - Command line interface (CLI)/graphical user interface (GUI)	
29.	SNMP V1, V2, V2C compatible monitoring	
30.	Field serviceable Power supplies and fans	
31.	Hot Swappable dual power supplies, compatible with the IPDU's supplied in the rack at GSDC	
32.	At least 100 licenses with 200 Keys (100 pairs)	

SECTION - 5
*Service Level Agreement, Penalties
&
Payment Terms*

SECTION – 5

5.1.1. Service Level and Penalty Clause

5.1.1 SLA defines the terms of the successful bidder’s responsibility in ensuring the performance on the agreed performance indicators as detailed in the agreement.

5.1.2 Escalation Procedure

The SLA provides Levels of support to be provided by the selected bidder, incident handling process of incident reported, incident escalation, responsible offices and expected time to resolve the incident. The following characteristics may be used to identify the severity of an incident.

- Business and financial exposure
- Work outage
- Number of end-users affected
- Work Around

5.1.3 Reporting of Call / Issue

The problems encountered during the usage of the HSM would be reported by TENDERER to the Help Desk of selected Bidder or through call log/escalation matrix (Name, Contact no. and e-mail id with responsibilities) provided by selected bidder to log complaints for further action of the reported problem. Also, the hours of operation & maintenance support would be 24x7x365 days. Successful bidder needs to share revised list of Contacts in case of any changes to avoid SLAs.

5.1.5 Penalty for Non-performance in required Service Levels/ Standards

If the selected bidder fails to deliver the required services due to reasons attributable to him like non-functioning of the HSM, etc. the cumulative penalty, as applicable, would be imposed as mentioned bellow while processing the payment for respective milestone

- a. Penalty for Downtime of HSM (including OS and other supplied S/w) deployed at project locations.

	Service Availability	Penalty
Service Availability	99.95% or Better	NO PENALTY
	99.50% to 99.94%	Rs. 5,000 of QP
	99.00 to 99.49%	Rs. 10,000 of QP
	98.50 to 98.99	Rs. 20,000 of QP
	< 98.50%	may lead to termination of contract

b. Penalty for Non-Availability of deployed engineer

Penalty Per Day of Non-Availability Support Engineer	Rs. 500/day
---	--------------------

- Any delay/ non-performance, not attributable to the selected bidder, shall not be considered while computing adherence to service levels but the selected bidder shall submit sufficient records/ documents that the delay/ non-performance is not on his part.

5.2. Payments Terms

Project Deliverables, Milestones Time& Payment Schedule

As mentioned above, following payment terms will be applied/adhere only after a formal work order is issued upon successful completion of project milestones:

T0: Award of Contract

S/N	Project Activity	Time Line	Deliverables	Payment	Penalty
1)	Supply, Installation, Integration, Testing and Commissioning of Network based Hardware Security Module (HSM) Appliance at GSDC site				
a)	Supply of Equipment and peripherals	T1 = T0+30 Days	- Delivery Challan of ordered items - OEM Warranty Certificates of Hardware & software items	50%	0.5% of Contract value of undelivered /delayed Items per week or part thereof for delay in delivery
b)	Installation, Integration & Testing & Commissioning at site	T2=T1+10 Days	- Installation Report - Testing report - Commissioning Report	20%	0.5% of Contract value of per week in installation & Commissioning of HSM
c)	03 Months after successful FAT		- Issue report for the said period.	20%	
2)	Comprehensive Warranty & Technical Support				
a)	Providing Technical Manpower Support & warranty for 05 years from date of FAT of HSMs.			Quarterly 10% + Salary (Rs. 40,000/M onth)	

5.2.1. Payment Procedure:

a.) Hardware/Material Component

i.) The successful bidder shall raise the component wise invoice against the milestones achieved (as mentioned above in the payment schedule) and submit the invoice to the TENDERER.

➔ Payment shall be made in Indian Rupees. While making payment, necessary income tax and service tax deductions will be made.

SECTION - 6
INSTRUCTIONS TO BIDDERS

SECTION - 6

6.1. General Instruction to Bidders

All information supplied by Bidders may be treated as contractually binding on the Bidders on successful award of the assignment by the TENDERER based on this RFP. No commitment of any kind, contractual or otherwise shall exist unless and until a formal written contract has been executed by or on behalf of the TENDERER. Any notification of preferred bidder status by the TENDERER shall not give rise to any enforceable rights by the Bidder. The TENDERER may cancel this public procurement at any time prior to a formal written contract being executed by or on behalf of the TENDERER.

This RFP supersedes and replaces any previous public documentation, communications, and Bidders should place no reliance on such communications. The TENDERER may terminate the RFP process at any time and without assigning any reason. The TENDERER makes no commitments, express or implied, that this process will result in a business transaction with anyone.

6.2. Cost of Bidding

- 6.2.1 The Bidder shall bear all costs associated with the preparation and submission of the Bid. The TENDERER will in no case be responsible for those costs, regardless of the conduct or outcome of the bidding process.
- 6.2.2 Bidder is requested to pay Rs. 5900/- (Including G.S.T.) as a bid processing fee (Non-refundable) in the form of demand draft in favour of "Gujarat Informatics Ltd." payable at Ahmedabad/Gandhinagar along with the EMD cover. In case of nonreceipt of bid processing fees & EMD the bid will be rejected by GIL/Dept. of Science & Technology as non-responsive.

6.3. Bidding Document

Bidder can download the bid document and further amendment if any freely available on <https://www.gil.gujarat.gov.in> and <https://www.gil.nprocure.com> and upload the same on <https://www.gil.nprocure.com> on or before due date of the tender. Bidder is expected to examine all instructions, forms, terms, and specifications in the bidding documents. Failure to furnish all information required by the bidding documents or submits a Bid not substantially responsive to the bidding documents in every respect may result in the rejection of the Bid. Under no circumstances physical bid will be accepted.

6.4. Clarification on Bidding Document

Bidders can seek written clarifications on or before pre-Bid to DGM (Tech), Gujarat Informatics Ltd., 8th Floor, and Block No. 1, Udyog Bhavan Gandhinagar 382017. GIL/Science & Technology Department will clarify & issue amendments if any to all the bidders in the pre-bid meeting. No further clarification what so ever will be entertained after the pre- bid meeting date.

6.5. Amendment of Bidding Documents

At any time prior to the deadline for submission of bids, the TENDERER, for any reason, whether at its own initiative or in response to the clarifications requested by prospective bidders may modify the bidding documents by amendment & put on our websites.

All prospective bidders are requested to browse our website & any amendments/ corrigendum/ modification will be notified on our website and such modification will be binding on them.

To allow prospective bidders a reasonable time to take the amendment into account in preparing their bids, the TENDERER, at its discretion, may extend the deadline for the submission of bids.

6.6. Language of Bid

The Bid prepared by the Bidder, as well as all correspondence and documents relating to the Bid exchanged by the Bidder and the TENDERER shall be in English. Supporting documents and printed literature furnished by the bidder may be in another language provided they are accompanied by an accurate translation of the relevant pages in English. For purposes of interpretation of the bid, the translation shall govern.

6.7. Bid Security/ Earnest Money Deposit (EMD)

6.7.1. Bidders shall submit, along with their Bids, EMD of Rs. 2,00,000/- , in the form of a Demand Draft OR in the form of an unconditional Bank Guarantee by Bank Guarantee (which should be valid for 6 months from the last date of bid submission) of any Nationalized Bank including the public sector bank or Private Sector Banks or Commercial Banks or Co-Operative Banks and Rural Banks (operating in India having branch at Ahmedabad/ Gandhinagar) as per the G.R. no. EMD/10/2016/328/DMO dated 01.05.2017 issued by Finance Department or further instruction issued by Finance department time to time; in the name of "Gujarat Informatics Ltd." payable at Gandhinagar (in the format specified in Format IV) and must be submitted along with the covering letter.

6.7.2. EMD of all unsuccessful bidders would be refunded by GIL within 60 Days on selection of successful bidder.

6.7.3. The EMD of the successful bidder would be returned upon successful submission of Performance Bank Guarantee as per the format provided in Format V

6.7.4. EMD amount is interest free and will be refundable to the unsuccessful bidders without any accrued interest on it.

6.7.5. The bid / proposal submitted without EMD and Bid Processing fee, mentioned above, will be summarily rejected.

6.7.6. The EMD may be forfeited, In case of a Bidder if:

6.7.6.1. The bidder withdraws its bid during the period of bid validity.

6.7.6.2. The Bidder does not respond to requests for clarification of their Bid.

6.7.6.3. The Bidder fails to co-operate in the Bid evaluation process.

6.7.6.4. In case of successful bidder, the said bidder fails:

6.7.6.4.1. Fails to sign the agreement in time

6.7.6.4.2. Fails to submit performance bank guarantee

6.8. Late Bids

- 6.8.1. Bids received after the due date and the specified time (including the extended period if any) for any reason whatsoever, shall not be entertained and shall be REJECTED.
- 6.8.2. The bids submitted by telex/telegram/ fax/e-mail etc. shall not be considered. No correspondence will be entertained on this matter.

6.9. Section Comprising the Bids

- 6.9.1. The quotation should be scan-able and distinct without any option stated in.
- 6.9.2. All forms / Tables, duly filled-in with necessary proofs, as required and stated in the bid document & supporting documents for eligibility criteria should be uploaded. The bid uploaded shall have the following documents:
- 6.9.2.1. **BID SECURITY SECTION:** The bid security & bid processing fee (non-refundable) to be furnished to GIL office in the form of demand draft in favour of "Gujarat Informatics Ltd." payable at Ahmedabad/Gandhinagar before the last date and time of the bid submission

6.9.2.2. ELIGIBILITY & TECHNICAL SECTION

- 1.) Financial Capabilities. (In the Prescribed Format: Format VII)
- 2.) Bidder's Experience. (In the Prescribed Format: Format VIII)
- 3.) Proposed Technical Solution as per the Scope of Work with details of each component/Module
- 4.) Proposed Technical Architecture for the project, with details of each project component
- 5.) Detailed Write-up on the Approach & Methodology for implementing and maintenance of the project.

6.9.2.3. PRICE BID SECTION: Priced bid (in the prescribed format only as given in this RFP)

- 6.9.3. Price shall be inclusive of all freight, forwarding, transit insurance and installation charges. Prices shall be inclusive of Excise Duties. The prices shall strictly be submitted in the given format. Quoted prices shall be without GST. The tax (GST) components as applicable shall be mentioned separately in the respective columns. Successful Bidder will have to supply/provide goods with an Invoice from a place located within State of Gujarat.
- 6.9.4. Prices shall be written in both words and figures. In the event of difference, the price in words shall be valid and binding. Arithmetical errors will be rectified on the following basis.
- 6.9.5. The bidder should provide calculations (Bill of Material with installation and setup charges, exclusive of taxes) for the quoted items, without which the bid is liable for rejection. Any arithmetical errors in these calculations will be on bidders account.
- 6.9.6. Offered price should be exclusive of all applicable taxes (anywhere in Gujarat state).

6.10. Bid Opening

- 6.10.1. Bids will be opened in the presence of Bidder's representatives, who choose to attend. The Bidder's representatives who are present shall sign a register evidencing their attendance.
- 6.10.2. In the event of the specified date of Bid opening being declared a holiday for the GIL, the Bids shall be opened at the appointed time and location on the next working day.
- 6.10.3. The Bidder's names, bid modifications or withdrawals, discounts and the presence or absence of relevant Bid security and such other details as the TENDERER officer at his/her discretion, may consider appropriate, will be announced at the opening.
- 6.10.4. Immediately after the closing time, the TENDERER contact person shall open the Un-Priced Bids and list them for further evaluation.
- 6.10.5. Bids that are not opened at bid opening shall not be considered further for evaluation.

6.11. Bid Validity

- 6.11.1. Bids shall remain valid for 180 days after the date of Bid opening prescribed by the TENDERER. A Bid valid for a shorter period shall be rejected as non-responsive.
- 6.11.2. In exceptional circumstances, the TENDERER may solicit Bidder's consent to an extension of the period of validity. The request and the responses thereto shall be made in writing. The Bid security shall also be suitably extended. A Bidder's request to modify the Bid will not be permitted.

6.12. Contacting the Tenderer

- 6.12.1. Bidder shall not approach the TENDERER officers outside of office hours and/ or outside the TENDERER office Premises, from the time of the Bid opening to the time the Contract is awarded. Any effort by a bidder to influence the TENDERER officers in the decisions on Bid evaluation, bid comparison or contract award may result in rejection of the Bidder's offer. If the Bidder wishes to bring additional information to the notice of the TENDERER, it should do so in writing.

6.13. Rejection of Bids

The TENDERER reserves the right to reject any Bid, and to annul the bidding process and reject all bids at any time prior to award of Contract, without thereby incurring any liability to the affected Bidder(s) or any obligation to inform the affected Bidder(s) of the grounds for such decision.

6.14. Bid Evaluation Process

6.14.1 The TENDERER will form a Committee which will evaluate the proposals submitted by the bidders for a detailed scrutiny. During evaluation of proposals, the TENDERER, may, at its discretion, ask the bidders for clarification of their Proposals.

6.14.2 **Pre-Qualification evaluation:**

6.14.2.1 Bidders who have submitted the valid EMD and non-refundable bid processing fee shall be considered for further evaluation. If bidders fail to submit the bid security and non-refundable bid processing fee as per this RFP document, the Bid shall be out rightly rejected.

6.14.3 **Financial Bid Evaluation**

The Financial Bids of qualified bidders only would be opened and evaluated to determine the L1 (lowest) bidder. In case of conditional bid or major deviations from the RFP requirements, the TENDERER may at its discretion reject the respective bid and will not be considered for further evaluation process.

6.15. Award of Contract

6.15.1 **Award Criteria:**

The Criteria for selection will be the lowest cost to the TENDERER for the qualified bid. The TENDERER may negotiate the prices with L1 Bidder, under each item/head offered by Bidder.

6.15.2 **The TENDERER right to vary requirements at time of award:**

The TENDERER reserves the right at the time of award to increase or decrease quantity for the requirements originally specified in the document without any change in Bid rate or other terms and conditions.

6.15.3 **In case, the lowest bidder does not accept the award of contract or found to be involved in corrupt and/or fraudulent practices, the next lowest bidder will be awarded the contract. In such scenario, the next lowest bidder must match the Lowest Bidder's Price and execute the project at the L1 Price for the entire contract duration.**

6.16. Notification of Award & Signing of Contract

6.16.1 Prior to expiration of the period of Bid validity, the TENDERER will notify the successful Bidders and issue Lol.

6.16.2 Within Seven (7) calendar days of receipt of the Contract Form, the successful Bidder shall sign and date the Contract and return it to the TENDERER along with contract Performance guarantee. The Performance Bank guarantee shall be equal to 10% of the contract value valid for duration of 180 days beyond the expiry of contract.

6.17. Force Majeure

6.17.1 Force Majeure shall mean any event or circumstances or combination of events or circumstances that materially and adversely affects, prevents or delays any Party in performance of its obligation in accordance with the terms of the Agreement, but only if and to the extent that such events and circumstances are not within the affected party's reasonable control, directly or indirectly, and effects of which could have prevented through Good Industry Practice or, in the case of construction activities through reasonable skill and care, including through the expenditure of reasonable sums of money. Any events or circumstances meeting the description of the Force Majeure which have same effect upon the performance of any contractor shall constitute Force Majeure with respect to the bidder. The Parties shall ensure compliance of the terms of the Agreement unless affected by the Force Majeure Events. The bidder shall not be liable for forfeiture of its implementation / Performance guarantee, levy of Penalties, or termination for default if and to the extent that its delay in performance or other failure to perform its obligations under the Agreement is the result of Force Majeure.

6.17.2 Force Majeure Events

The Force Majeure circumstances and events shall include the following events to the extent that such events or their consequences (it being understood that if a causing event is within the reasonable control of the affected party, the direct consequences shall also be deemed to be within such party's reasonable control) satisfy the definition as stated above. Without limitation to the generality of the foregoing, Force Majeure Event shall include following events and circumstances and their effects to the extent that they, or their effects, satisfy the above requirements:

6.17.3 **Natural events** ("Natural Events") to the extent they satisfy the foregoing requirements including:

- 6.17.3.1 Any material effect on the natural elements, including lightning, fire, earthquake, cyclone, flood, storm, tornado, or typhoon;
- 6.17.3.2 Explosion or chemical contamination (other than resulting from an act of war);
- 6.17.3.3 Epidemic such as plague;
- 6.17.3.4 Any event or circumstance of a nature analogous to any of the foregoing.

6.17.4 **Other Events** ("Political Events") to the extent that they satisfy the foregoing requirements including:

- 6.17.4.1 Political Events which occur inside or Outside the State of Gujarat or involve directly the State Government and the Central Government ("Direct Political Event"), including:
 - Act of war (whether declared or undeclared), invasion, armed conflict or act of foreign enemy, blockade, embargo, revolution, riot, insurrection, civil commotion, act of terrorism or sabotage;
 - Strikes, work to rules, go-slows which are either widespread, nation-wide, or state-wide or are of political nature;
 - Any event or circumstance of a nature analogous to any of the foregoing.

6.17.5 **FORCE MAJEURE EXCLUSIONS:**

Force Majeure shall not include the following event(s) and/or circumstances, except to the extent that they are consequences of an event of Force Majeure:

5.17.5.1 Unavailability, late delivery

5.18.5.2 Delay in the performance of any contractor, sub-contractors or their agents;

6.17.6 **PROCEDURE FOR CALLING FORCE MAJEURE:**

The Affected Party shall notify to the other Party in writing of the occurrence of the Force Majeure as soon as reasonably practicable, and in any event within 5 (five) days after the Affected Party came to know or ought reasonably to have known, of its occurrence and that the Force Majeure would be likely to have a material impact on the performance of its obligations under the Agreement.

6.18. Contract Obligations

Once a contract is confirmed and signed, the terms and conditions contained therein shall take precedence over the Bidder's bid and all previous correspondence.

6.19. Amendment to the Agreement

Amendments to the Agreement may be made by mutual agreement by both the Parties. No variation in or modification in the terms of the Agreement shall be made except by written amendment Signed by both the parties. All alterations and changes in the Agreement will consider prevailing rules, regulations and laws applicable in the state of Gujarat.

6.20. Representations and Warranties

6.20.1. Representations and Warranties by the Selected Agency:

- 6.20.1.1. It is a company/ organization under any statute of India duly organized and validly existing under the laws of India and has all requisite legal power and authority and corporate authorizations to execute the Agreement and carry out the terms, conditions and provisions hereof;
- 6.20.1.2. It has in full force and effect all requisite clearances, approvals and permits necessary to enter into the Agreement and perform its obligations hereof;
- 6.20.1.3. It will have the legally valid and enforceable title to all Equipment as may be necessary for proper functioning and it will be free from all encumbrances, liens, charges, any security interest and adverse claims of any description;
- 6.20.1.4. The Agreement and the transactions and obligations hereof do not contravene its constitutional documents or any law, regulation or government directive and will not contravene any provisions of, or constitute a default under, any other Agreement or instrument to which it is a party or by which it or its property may be bound or any of its obligations or undertakings by which it or any of its assets are bound or cause a limitation on its powers or cause it to exceed its authorized powers;
- 6.20.1.5. There is no pending or threatened actions, suits or proceedings affecting the selected agency or its affiliates or any of their respective assets before a court, governmental agency, commission or arbitrator or administrative tribunal which affects the selected agency's ability to perform its obligations under the Agreement; and neither selected agency nor any of its affiliates have immunity from the jurisdiction of a court or from legal process (whether through service of notice, attachment prior to judgment, attachment in aid of execution or otherwise);
- 6.20.1.6. The selected agency confirms that all representations and warranties of the selected agency set forth in the Agreement are true, complete and correct in all respects;
- 6.20.1.7. No information given by the selected agency in relation to the Agreement, project documents or any document comprising security contains any material misstatement of fact or omits to state as fact which would be materially averse to the enforcement of the rights and remedies of the TENDERER or which would be necessary to make any statement, representation or warranty contained herein or therein true and correct;
- 6.20.1.8. All equipment including material to be installed by the selected agency shall be new. All equipment shall conform to the codes, standards and regulations applicable to networking facilities and benefit from the usual manufacturer's guarantees.

6.20.2. Representations and Warranties by the TENDERER

- 6.20.2.1. It has full legal right; power and authority to execute the said project and to enter into and perform its obligations under the Agreement and there are no proceedings pending.
- 6.20.2.2. The Agreement has been duly authorized, executed and delivered by the TENDERER and constitutes valid, legal and binding obligation of TENDERER.
- 6.20.2.3. The execution and delivery of the Agreement with the selected agency does not violate any statutory judgment, order, decree, regulation, right, obligation or rule of any court, government authority or arbitrator of competent jurisdiction applicable in relation to the TENDERER, its assets or its administration.

6.21. Resolution of Disputes

- 6.21.1 If any dispute arises between the Parties hereto during the subsistence or thereafter, in connection with the validity, interpretation, implementation or alleged material breach of any provision of the Agreement or regarding a question, including the questions as to whether the termination of the Contract Agreement by one Party hereto has been legitimate, both Parties hereto shall endeavour to settle such dispute amicably. The attempt to bring about an amicable settlement is considered to have failed as soon as one of the Parties hereto, after reasonable attempts [which attempt shall continue for not less than 30 (thirty) days], give 15 days' notice thereof to the other Party in writing.
- 6.21.2 In the case of such failure the dispute shall be referred to a sole arbitrator or in case of disagreement as to the appointment of the sole arbitrator to three arbitrators, two of whom will be appointed by each Party and the third appointed by the two arbitrators.
- 6.21.3 The place of the arbitration shall be Gandhinagar, Gujarat.
- 6.21.4 The Arbitration proceeding shall be governed by the Arbitration and Conciliation Act of 1996 as amended.
- 6.21.5 The proceedings of arbitration shall be in English language.
- 6.21.6 The arbitrator's award shall be substantiated in writing. The arbitration tribunal shall also decide on the costs of the arbitration procedure.
- 6.21.7 The Parties hereto shall submit to the arbitrator's award and the award shall be enforceable in any competent court of law

6.22. Books & Records

The selected agency shall maintain adequate Documents Related to project's physical materials & equipment's for inspection and audit by the TENDERER during the terms of Contract until expiry of the performance guarantee.

6.23. Warranty Terms

If the materials supplied do not meet the specifications and / or are not in accordance with the Scope of work set out in this order, and rectification is required, The TENDERER shall notify the Successful bidder giving full details of difference. The Successful bidder shall attend to such materials (at specified locations) within seven (07) days of receipt of such notice to meet and agree with representatives of the TENDERER, the action required to correct the deficiency. Should the Successful bidder fail the attend meeting at locations within the time specified above, the

TENDERER shall be at liberty to rectify the work/materials and Successful bidder shall reimburse the TENDERER all costs and expenses incurred in connection with such trouble or defect.

6.24. Performance Guarantee

- 6.24.1 The Selected agency shall furnish Performance Guarantee as provided in the bid document to the TENDERER for an amount equal to 10% of the value of Order.
- 6.24.2 The performance guarantee will be in the form of bank guarantee for the amount equal of 10% of the value of the Order / LOI towards faithful performance of the contract obligation, and performance of the equipment during Warranty period. In case of poor and unsatisfactory field services, the TENDERER shall invoke the PBG.
- 6.24.3 The Performance Guarantee shall be valid for a period of 180 days beyond Contract period and shall be denominated in Indian Rupees and shall be in the form of an unconditional Bank Guarantee issued by all Public-Sector Banks / private banks having branch in Gandhinagar\Ahmedabad in the format provided by the TENDERER to be submitted Within 15 calendar days from the date of final work order.
- 6.24.4 The Performance Guarantee shall be discharged by the TENDERER and returned to the successful bidder within 30 calendar days from the date of expiry of the Performance Bank Guarantee.

6.25. Termination Clause

- 6.25.1 **Termination by the TENDERER:**

The TENDERER, reserves the right to suspend any of the services and/or terminate this agreement in the following circumstances by giving 30 days' notice in writing if: -

 - 6.25.1.1 The bidder becomes the subject of bankruptcy, insolvency, and winding up, receivership proceedings;
 - 6.25.1.2 In case the TENDERER finds illegal use of hardware, software tools, manpower etc. that are dedicated to the project;
 - 6.25.1.3 In case the bidder fails to deliver, Installed and commission ordered items within the prescribed time lines and extension granted if any. In such scenario, the TENDERER reserves the right to procure the same from other bidders at the risk, cost and responsibility of the selected agency.
- 6.25.2 Termination by Successful bidder: The successful bidder reserves the right to suspend any of the Services and/or terminate the Agreement at any time with 30 days' notice if the payment to the selected is due for more than 2 (two) consecutive quarters.
- 6.25.3 Upon occurrence of an event of default as set out in Clause above, either party will deliver a default notice in writing to the other party which shall specify the event of default, and give the other party an opportunity to correct the default.
- 6.25.4 Upon expiry of notice period unless the party receiving the default notice remedied the default, the party giving the default notice may terminate the Agreement.
- 6.25.5 During the notice period, both parties shall, save as otherwise provided therein, continue to perform their respective obligations under this Agreement and shall not, whether by act of omission or commission impede or otherwise interfere with party's endeavour to remedy the default which gave rise to the commencement of such notice period.
- 6.25.6 The termination hereof shall not affect any accrued right or liability of either Party nor affect the operation of the provisions of the Contract that are expressly or by implication intended to come into or continue in force on or after such termination.

6.26. Indemnification

Selected agency will defend and/or settle any claims against the TENDERER that allege that Bidder branded product or service as supplied under this contract infringes the intellectual property rights of a third party. Selected agency will rely on Customer's prompt notification of the claim and cooperation with our defence. Bidder may modify the product or service so as to be non-infringing and materially equivalent or we may procure a license. If these options are not available, we will refund to Customer the amount paid for the affected product in the first year or the depreciated value thereafter or, for support services, the balance of any pre-paid amount or, for professional services, the amount paid. Bidder is not responsible for claims resulting from any unauthorized use of the products or services. This section shall also apply to deliverables identified as such in the relevant Support Material except that Bidder is not responsible for claims resulting from deliverables content or design provided by Customer.

6.27. Limitation of Liability

Selected agency's cumulative liability for its obligations under the contract shall not exceed the value of the charges payable by the TENDERER within the remaining duration of the contract term from the day claim is raised and selected agency shall not be liable for incidental, consequential, or indirect damages including loss of profit or saving.

6.28. Confidentiality

- 6.28.1 Selected agency understands and agrees that all materials and information marked and identified by the TENDERER as 'Confidential' are valuable assets of the TENDERER and are to be considered GIL/DST proprietary information and property. Selected agency will treat all confidential materials and information provided by the TENDERER with the highest degree of care necessary to ensure that unauthorized disclosure does not occur. Selected agency will not use or disclose any materials or information provided by GIL/DST without its prior written permission.
- 6.28.2 Selected agency shall not be liable for disclosure or use of any materials or information provided by the TENDERER or developed by selected agency which is:
 - 6.28.2.1 Possessed by selected agency prior to receipt from the TENDERER, other than through prior disclosure by the TENDERER, as documented by selected agency's written records;
 - 6.28.2.2 Published or available to the general public otherwise than through a breach of Confidentiality; or
 - 6.28.2.3 Obtained by selected agency from a third party with a valid right to make such disclosure, provided that said third party is not under a confidentiality obligation to the TENDERER; or
 - 6.28.2.4 Developed independently by the selected agency.
- 6.28.3 If selected agency is required by judicial or administrative process to disclose any information or materials required to be held confidential hereunder, selected agency shall promptly notify the TENDERER and allow reasonable time to oppose such process before making disclosure.

- 6.28.4 Selected agency understands and agrees that any use or dissemination of information in violation of this Confidentiality Clause will cause the TENDERER irreparable harm, may leave the TENDERER with no adequate remedy at law and the TENDERER is entitled to seek to injunctive relief.
- 6.28.5 The TENDERER does not follow the practice of asking Confidential Information of selected agency, however if any confidential information is required/shared by the selected agency then selected agency must clearly marked it as "Strictly confidential". The TENDERER in turn will not share the same without prior concern of the selected agency.
- 6.28.6 Above mentioned "confidentiality clause" shall be applicable on both the parties i.e. the TENDERER and the successful bidder.

6.29. Service Terms

- 6.29.1 The entire scope of the work depends on the technical skill and experience in management of the same level or kind of capabilities.
- 6.29.2 It is mandatory for Bidder to deploy qualified professional to install, commission & maintain the proposed applications, as defined under scope of work.
- 6.29.3 The Bidder must submit regular schedule of man power availability & get it approved by the TENDERER, before deployment.
- 6.29.4 The Bidder will have to carry out reinstallation of any of the software equipment 'Free of Cost, if required.
- 6.29.5 The Bidder need to manage & maintain various records related to the services extended to the Government.
- 6.29.6 If required, the Bidder may need to coordinate and approach various agencies working for the TENDERER.
- 6.29.7 The Bidder needs to maintain the required Information security of the databases as per the TENDERER'S Security guidelines.
- 6.29.8 The Bidder is responsible to maintain documentation on the progress of the work and will have to update the same on regular basis. Successful bidder will have to submit the progress reports regularly, as per the guide line issued by the TENDERER.
- 6.29.9 In case of any upgrade, customization and patches the bidder will have to take necessary permission from the TENDERER.
- 6.29.10 All expenses related to installation, testing and deployment, must be borne by the Bidder as part of Contract Agreement.
- 6.29.11 Bidder shall submit test procedures covering various test cases and expected results of these tests relating to various systems being commissioned.

6.30. Warranty Support

- 6.30.1 Bidder shall provide a comprehensive on site free support for 5 years from the date of FAT for the HSM Solution as in the RFP.
- 6.30.2 Bidder shall provide the comprehensive support in respect of proper design, quality and security for the HSM solution as mentioned in the RFP. Bidder must warrant all software procured/developed and implemented as per this RFP against any bugs/issues during the support period.
- 6.30.3 Bidder shall provide the performance warranty in respect of performance of the installed Hardware / software to meet the performance requirements and service levels in the RFP.

- 6.30.4 Bidder is responsible for sizing and procuring the necessary software/database licenses as per the performance requirements provided in the RFP. During the warranty period, bidder shall augment or procure additional licenses at no additional cost in case the procured hardware or software is not adequate to meet the service levels.
- 6.30.5 The bidder shall carry out Preventive Maintenance (PM), including cleaning of interior and exterior, of all hardware and testing for virus, if any, and should maintain proper records at each site for such PM. Failure to carry out such PM will be a breach of warranty and the warranty period will be extended by the period of delay in PM.
- 6.30.6 Bidder shall monitor warranties to check adherence to preventive and repair maintenance terms and conditions.
- 6.30.7 Bidder shall ensure that the warranty complies with the agreed Technical Standards, Security Requirements, Operating Procedures, and Recovery Procedures.

6.31. Fraudulent and Corrupt Practices

- 6.31.1 Fraudulent practice means a misrepresentation of facts to influence a procurement process or the execution of a Contract and includes collusive practice among Bidders (prior to or after Bid submission) designed to establish Bid prices at artificial non-competitive levels and to deprive the TENDERER of the benefits of free and open competition.
- 6.31.2 "Corrupt Practice" means the offering, giving, receiving or soliciting of anything of value, pressurizing to influence the action of a public official in the process of Contract execution.
- 6.31.3 The TENDERER will reject a proposal for award and may forfeit the EMD and/or Performance Bank Guarantee if it determines that the bidder recommended for award has engaged in corrupt or fraudulent practices in competing for, or in executing, contract(s).

6.32. Acceptance Tests

Acceptance Test will be conducted in as follows:

- 6.32.1 TENDERER reserves the right to inspect goods and services supplied as per the scope of this RFP document. The cost of all such tests shall be borne by the Vendor. Any inspected goods fail for confirm to the specification will be rejected, and Vendor shall have to replace the rejected goods as per the contract specification without any financial implication to the TENDERER.
- 6.32.2 Final Acceptance Test (FAT): After successful installation of the System in accordance with the requirements as mentioned in Schedule of Requirement, Final Acceptance Test will be conducted. After successful testing, Acceptance Test Certificate will be issued by TENDERER or its designated agency to the Vendor.
- 6.32.3 The date on which Acceptance certificate is issued shall be deemed to be the date of successful commissioning of the System.
- 6.32.4 Any delay by the Vendor in the Acceptance Testing shall render the Vendor liable to the imposition of appropriate Penalties.
- 6.32.5 Bidder is required to update the details of Hardware installed in the Assets Master of IWDMS and the TENDERER before completion of FAT.

6.33. Copyright and Intellectual Property Rights

- 6.33.1 The TENDERER will have exclusive right to use and own the application software (as customized from time to time), its source code along with further development rights and its derivatives. The software prepared cannot be used for any purpose whatsoever without the written consent of the TENDERER.
- 6.33.2 No software or services covered by the contract shall be developed or done by the company in violation of any right whatsoever of third party, and in particular, but without prejudice to the generality of the foregoing of any patent right, trademark or Similar right, or of any charge, mortgage or lien. Vendor will indemnify the TENDERER for all such correspondence.

6.34. Approvals/Clearances

- 6.34.1 Necessary approvals/ clearances concerned authorities, for establishing the proposed project needs to be obtained by the selected agency.
- 6.34.2 Necessary approvals/ clearances from concerned authorities, as required, for fire protection, government duties / taxes/ Octroi needs to be obtained by the Selected agency.

6.35. License Management

- a. All the software licenses should be in the name of the TENDERER
- b. The successful bidder shall avoid the unauthorized usage of Licensed Software. In the event of any claim asserted by Third Party of Infringement of Copyright, Patent or Trademark arising from the use of IT components or software, the bidder shall be entirely responsible to extinguish such a claim. If the bidder fails to comply and the TENDERER is required to pay the compensation to the Third Party resulting from such infringement, the Bidder shall be responsible for the compensation including all expenses, court costs and lawyer fees.

SECTION - 7
FINANCIAL BID

SECTION - 7

FINANCIAL BID FORMAT

Sr. No.	ITEM	Qty. (In Nos.)	Unit Price (In Rs. Without tax)	Total Price (In Rs. Without tax)	Rate of GST (%)
A	B	C	D	E = C*D	F
1	Hardware Security Module (HSM)	02			
GRAND TOTAL					

Note:

- L1 will be the lowest sum total of rate without tax.
- The warranty will be of 05 years.
- The Bidder shall explicitly mention the applicable rate of GST.
- Supply & installation of the above-mentioned materials should be carried out by the successful bidder at Centers as mentioned by TENDERER across the Gujarat State.
- Successful Vendor will have to supply/provide goods with an Invoice from a place located within State of Gujarat.
- The above-mentioned quantity of the item is estimated and for evaluation purpose only. However, at the time of issue of order, the actual quantity will be considered based on the requirements.

SECTION - 8
ANNEXURES & FORMATS

Format I – Proposal Covering Letter

(To be on the Bidder's letterhead duly Signed by Authorized Signatory)

Tender Ref No:

To

DGM (Tech)

Gujarat Informatics Ltd.

Block no. 1, 8th floor, Udyog Bhavan,

Sector-11, Gandhinagar

Ref: RFP for Selection of Agency for Supply, Installation, Commissioning & Maintenance of Hardware Security Module for Department of Science & Technology, Gandhinagar (Tender No. HWT181017472).

Dear Sir,

We (Name of the bidder) hereby submit our proposal in response to notice inviting tender date and tender document no. and confirm that:

1. All information provided in this proposal and in the attachments, is true and correct to the best of our knowledge and belief.
2. We shall make available any additional information if required to verify the correctness of the above statement.
3. Certified that the period of validity of bids is 180 days from the last date of submission of proposal, and
4. We are quoting for all the items (including services) as per the price bid format Section-VII as mentioned in the RFP.
5. We the Bidder are not under a declaration of Ineligibility for corrupt or fraudulent practices or blacklisted by any of the Government agencies.
6. We have an office in the state and relevant documents for the same are attached. We undertake that if the local presence is not there in the state, that we shall establish an office at Gandhinagar/ Ahmedabad, within 45 days from the date of the award of contract.
7. Gujarat Informatics Limited may contact the following person for further Information regarding this tender: -
 - a. Name & Designation:
 - b. Full address of office
 - c. Email ID & Contact No.
8. We are uploading our Response to the RFP (Eligibility, technical and financial bid documents) as per the instructions set out in this RFP.

Yours Sincerely,

(Signature)

Name of Authorized Signatory:

Designation:

Date:

Name of the bidder:

Format II: Format for Power of Attorney

(To be provided in original on stamp paper of value required under law duly Signed by 'bidder')

Dated:

POWER OF ATTORNEY To Whomsoever It May Concern

Know all men by these presents, we _____ (name and registered office address of the Bidder) do hereby constitute, appoint and authorize Mr./Ms./Mrs. _____ (Name of the Person(s)), domiciled at _____ (Address), acting as _____ (Designation and the name of the firm), as Authorized Signatory and whose Signature is attested below, as our attorney, to do in our name and on our behalf, all such acts, deeds and things necessary in connection with or incidental to our Proposal for award of Contract "**RFP for Selection of Agency for Supply, Installation, Commissioning & Maintenance of Hardware Security Module for Department of Science & Technology, Gandhinagar (Tender No. HWT181017472).**" involving the deliverables including Provisioning for Software, Networking and IT infrastructure,

Implementation Services, Operations, Maintenance and support for at least 5 years as per location provided in RFP issued by GIL , vide RFP (Tender Document) Document No. _____ dated _____ , issued by Gujarat Informatics Limited, including Signing and submission of all documents and providing information and responses to clarifications / enquiries etc. as may be required by Gujarat Informatics Limited or any governmental authority, representing us in all matters before Gujarat informatics Limited, and generally dealing with GIL in all matters in connection with our Proposal for the said Project. We hereby agree to ratify all acts, deeds and things lawfully done by our said attorney pursuant to this Power of Attorney and that all acts, deeds and things done by our aforesaid attorney shall and shall always be deemed to have been done by us.

For -----

(Signature)

(Name, Title and Address)

Accept (Attested Signature of Mr./Ms./Mrs. _____)

(Name, Title and Address of the Attorney)

Notes: To be executed by the Bidder - The mode of execution of the Power of Attorney should be in accordance with the procedure, if any, laid down by the applicable law and the charter documents of the executant(s) and when it is so required the same should be under common seal affixed in accordance with the required procedure. - Also, wherever required, the executant(s) should submit for verification the extract of the charter documents and documents such as a resolution / power of attorney in favour of the Person executing this Power of Attorney for the delegation of power hereunder on behalf of the executants(s).

Format III - Authorization Letter from Original Equipment Manufacturer (OEM)

(To be provided as part of Technical Bid on letter head Signed by the authorized representative of OEM in favour of 'bidder')

To
DGM (Tech)
Gujarat Informatics Ltd
Block no. 1, 8th floor, Udyog Bhavan,
Sector-11, Gandhinagar

Tender Ref No:

Ref: RFP for Selection of Agency for Supply, Installation, Commissioning & Maintenance of Hardware Security Module for Department of Science & Technology, Gandhinagar (Tender No. HWT181017472).

Dear Sir,

I/We [manufacturer] having our office/works athereby certify that M/s [Bidder] is an authorized [relationship] of [manufacturer] and they are authorized to represent [manufacturer] in submitting their bid for [product& services] and conclude the contract with you.

We [manufacturer] are confident of M/s [Bidder's] ability to represent us and provide full support in making your project successful. We [manufacturer] have authorized to quote for this tender.

I / We hereby commit & confirm the following:

- a) The duration of the service support will be for a period of five years from the date of supply of equipment.
- b) The service support will be provided onsite and will not be charged extra.
- c) The service support will be comprehensive hence no extra charge is to be paid for any Hardware failure.

Signature

Name

Designation

Format IV- Bank Guarantee format for Earnest Money Deposit

To
DGM (Tech)
Gujarat Informatics Ltd
Block no. 1, 8th floor, Udyog Bhavan,
Sector-11, Gandhinagar

Dated:

Whereas ----- (here in after called "the Bidder") has submitted its bid dated ----- in response to the Tender no: XXXXXXXXX for ----- KNOW ALL MEN by these presents that WE ----- having our registered office at ----- (hereinafter called "the Bank") are bound unto the _____, Gujarat Informatics Limited in the sum of ----- for which payment well and truly to be made to Gujarat Informatics Limited , the Bank binds itself, its successors and assigns by these presents. Sealed with the Common Seal of the said Bank this -----day of -----2017.

THE CONDITIONS of this obligation are:

The EMD may be forfeited, In case of a Bidder if:

- 1) The bidder withdraws its bid during the period of bid validity.
 - a. The Bidder does not respond to requests for clarification of their Bid.
 - b. The Bidder fails to co-operate in the Bid evaluation process.
 - c. The bidder, fails to furnish Performance Bank Guarantee in time.
- 2) The bidder fails to Sign the contract in accordance with this RFP
- 3) The bidder is found to be involved in fraudulent and corrupt practices

We undertake to pay to the GIL up to the above amount upon receipt of its first written demand, without GIL having to substantiate its demand, provided that in its demand GIL will specify that the amount claimed by it is due to it owing to the occurrence of any of the above-mentioned conditions, specifying the occurred condition or conditions.

This guarantee will remain valid up to 6 months from the last date of bid submission. The Bank undertakes not to revoke this guarantee during its currency without previous consent of the GIL and further agrees that the guarantee herein contained shall continue to be enforceable till the GIL discharges this guarantee The

Bank shall not be released of its obligations under these presents by any exercise by the GIL of its liability with reference to the matters aforesaid or any of them or by reason or any other acts of omission or commission on the part of the GIL or any other indulgence shown by the GIL or by any other matter or things.

The Bank also agree that the GIL at its option shall be entitled to enforce this Guarantee against the Bank as a Principal Debtor, in the first instance without proceeding against the SELLER and not withstanding any security or other guarantee that the TENDERER may have in relation to the SELLER's liabilities.

Dated at _____ on this _____ day of _____ 2017.

Signed and delivered by

For & on Behalf of
Name of the Bank & Branch &
Its official Address with seal

Approved Bank: All Nationalized Bank including the public sector bank or Private Sector Banks or Commercial Banks or Co-Operative & Rural Banks (operating in India having branch at Ahmedabad/ Gandhinagar) as per the G.R. no. EMD/10/2015/508/DMO dated 27.04.2016 issued by Finance Department or further instruction issued by Finance department time to time.

Format-V- PERFORMANCE BANK GUARANTEE

(To be stamped in accordance with Stamp Act)

Ref:

Bank Guarantee No.

Date:

To,

DGM (Tech)

Gujarat Informatics Ltd

Block no. 1, 8th floor, Udyog Bhavan,

Sector-11, Gandhinagar

Dear Sir,

WHEREAS..... (Name of Bidder) hereinafter called "the Bidder" has undertaken, in pursuance of Agreement dated, (hereinafter referred to as "the Agreement for ***RFP for Selection of Agency for Supply, Installation, Commissioning & Maintenance of Hardware Security Module for Department of Science & Technology, Gandhinagar (Tender No. HWT181017472).***", for the Department of Science & Technology, Government of Gujarat.

AND WHEREAS it has been stipulated in the said Agreement that the Bidder shall furnish a Bank Guarantee ("the Guarantee") from a scheduled bank for the sum specified therein as security for implementing PROJECT.

1. WHEREAS we _____ ("the Bank", which expression shall be deemed to include it successors and permitted as Signs) have agreed to give the Gujarat Informatics Limited ("GIL") the Guarantee:

THEREFORE, the Bank hereby agrees and affirms as follows:

The Bank hereby irrevocably and unconditionally guarantees the payment of all sums due and payable by the Bidder to GIL under the terms of their Agreement dated _____. Provided, however, that the maximum liability of the Bank towards GIL under this Guarantee shall not, under any circumstances, exceed _____ in aggregate.

2. In pursuance of this Guarantee, the Bank shall, immediately upon the receipt of a written notice from GIL in that behalf and without delay/demur or set off, pay to GIL any and all sums demanded by GIL under the said demand notice, subject to the maximum limits specified in Clause 1 above. A notice from GIL to the Bank shall be sent by Registered Post (Acknowledgement Due) at the following address:

Attention Mr. _____.

3. This Guarantee shall come into effect immediately upon execution and shall remain in force for a period of months from the date of its execution. The Bank shall extend the Guarantee for a further period which may mutually decided by the bidder and GIL.

The liability of the Bank under the terms of this Guarantee shall not, in any manner whatsoever, be modified, discharged, or otherwise affected by:

- Any change or amendment to the terms and conditions of the Contract or the execution of any further Agreements.
- Any breach or non-compliance by the Bidder with any of the terms and conditions of any Agreements/credit arrangement, present or Future, between Bidder and the Bank.

4. The BANK also agrees that GIL at its option shall be entitled to enforce this Guarantee against the Bank as a Principal Debtor, in the first instance without proceeding against the BIDDER and notwithstanding any security or other guarantee that GIL may have in relation to the Bidder's liabilities.

5. The BANK shall not be released of its obligations under these presents by reason of any act of omission or commission on the part of GIL or any other indulgence shown by GIL or by any other matter or thing whatsoever which under law would, but for this provision, have the effect of relieving the BANK.

6. This Guarantee shall be governed by the laws of India and the courts of Gandhinagar shall have jurisdiction in the adjudication of any dispute which may arise hereunder.

Dated this Day of,2017

Witness

(Signature)
(Name)

(Official Address)

Dated:

(Signature)
Bank Rubber Stamp
(Name)
Designation with Bank Stamp
Plus Attorney as per Power of
Attorney No.

Approved Bank: All Nationalized Bank including the public sector bank or Private Sector Banks or Commercial Banks or Co-Operative & Rural Banks (operating in India having branch at Ahmedabad/ Gandhinagar) as per the G.R. no. EMD/10/2015/508/DMO dated 27.04.2016 issued by Finance Department or further instruction issued by Finance department time to time.

**Format VI OEM Undertaking for Back-to-Back OEM Warranty and support for 5Years
(On OEM letter Head signed by Authorized Signatory)**

Ref:

Date: ___ / ___ / 20__

To,
DGM (Tech)
Gujarat Informatics Ltd
Block no. 1, 8th floor, Udyog Bhavan,
Sector-11, Gandhinagar

Dear Sir,

Ref : RFP no. HWT181017472

**Subject : OEM undertaking for back to back OEM warranty and support for the
quoted products in the RFP no. HWT181017472**

Dear Sir,

We, _____, with address _____

_____, do hereby confirm that we will be offering _____
_____ as part of our solution for the above mentioned RFP.

We hereby confirm that the offered Products in the referenced RFP will be provided with a **back to back 24x7x365 warranty and support** including subscription covering upgrades, updates, patch updates, bug fixes, Fault Reporting, Trouble Ticketing, call resolution etc. available for the period of 05 (Five) years for the Proposed Solution through M/s. _____ (SI/Bidder) from the date of Go-Live and also till Go-live.

Thanking you,

(_____)

Authorized Signatory

Note:

Power of Attorney should be enclosed with the document confirming the signing person as an authorized signatory.

Format VII- Financial Details of the Bidder

Turnover (In Crore)			Net Worth (In Crore)		
2014 – 15	2015 – 16	2016 – 17	2014 – 15	2015 – 16	2016 – 17

Note:

1. Upload the audited financial statement/ audited annual report of the last three financial years.
2. Annual financial turnover during the last three years is ____ Crore (each year) against System Integration and Services. Bidder shall upload a certificate from the statutory auditors.
3. Bidder should have a positive Net worth. In this regard bidder, should upload a certificate from the statutory auditors.

Name:

Designation:

Signature of the Authorized Signatory (with seal):

Format VIII- Bidder's Experience

DETAILS OF PAST EXPERIENCE

Sr #	Client Name & Address	Project Name	Nos. of Devices deployed	Contact details (Name, Designation, Phone No., Email ID)
1				
2				
3				

Note:

1. Upload the copy of successful work completion/Work in Progress certificates from client, Work Order/ Purchase Order, Self-certificate of completion or work order and phase completion certificate from client etc.
1. Please mention only those projects which meet the eligibility criteria bidder.

Name:

Designation:

Signature of the Authorized Signatory (with seal):

CONTRACT FORM

THIS AGREEMENT made on the _____ day of _____, 2016 ____ Between _____ (Name of purchaser) of _____ (Country of Purchaser) hereinafter "the Purchaser" of the one part and _____ (Name of Supplier) of _____ (City and Country of Supplier) hereinafter called "the Supplier" of the other part :

WHEREAS the Purchaser is desirous that certain Goods and ancillary services viz., _____ (Brief Description of Goods and Services) and has accepted a bid by the Supplier for the supply of those goods and services in the sum of _____ (Contract Price in Words and Figures) hereinafter called "the Contract Price in Words and Figures" hereinafter called "the Contract Price."

NOW THIS AGREEMENT WITNESSETH AS FOLLOWS:

- 1 In this Agreement words and expressions shall have the same meanings as are respectively assigned to them in the Conditions of Contract referred to.
- 2 The following documents shall be deemed to form and be read and construed as part of this Agreement, viz. :
 - 2.1 the Bid Form and the Price Schedule submitted by the Bidder;
 - 2.2 terms and conditions of the bid
 - 2.3 the Purchaser's Notification of Award
- 3 In consideration of the payments to be made by the Purchaser to the Supplier as hereinafter mentioned, the Supplier hereby covenants with the Purchaser to provide the goods and services and to remedy defects therein in conformity in all respects with the provisions of the Contract.
- 4 The Purchaser hereby covenants to pay the Supplier in consideration of the provision of the goods and services and the remedying of defects therein, the Contract Price or such other sum as may become payable under the provisions of the Contract at the times and in the manner prescribed by the Contract.
- 5 Particulars of the goods and services which shall be supplied / provided by the Supplier are as enlisted in the enclosed annexure :

TOTAL VALUE:

DELIVERY SCHEDULE:

IN WITNESS whereof the parties hereto have caused this Agreement to be executed in accordance with their respective laws the day and year first above written.

Signed, Sealed and Delivered by the

Said _____ (For the Purchaser)

in the presence of _____

Signed, Sealed and Delivered by the

Said _____ (For the Supplier)

in the presence of _____