

Bid Document



GUJARAT INFORMATICS LIMITED

Block No. 1, 8th Floor, Udyog Bhavan,
Sector-11, Gandhinagar 382 010
Phone No: 079 - 23256022
Fax No: 079 - 23238925

**Bid for Supply, Installation, Commissioning
and Maintenance of Server, Storage & related
Equipments for GIS based Application on behalf of
Bhaskaracharya Institute for Space Applications
and Geo-Informatics (BISAG), Gandhinagar
(Tender No. HWT140818506)**

Pre-bid meeting: 24.08.2018 on 1500 hours

Last Date of Submission of Bid: 06.09.2018 till 1500 hours

Last Date of Submission of Bid Processing Fees & EMD: 06.09.2018 till 1500 hours

Date of Opening of Technical Bid: 06.09.2018 on 1700 hours

Bid Processing Fee: Rs. 17,700/-

Introduction

Gujarat Informatics Limited (herein after referred to as GIL), on behalf of Bhaskaracharya Institute for Space Applications and Geo-Informatics (BISAG), Gandhinagar (herein after referred to as the Purchasers) for their requirements of purchase of Server, Storage & related Equipments, intend to invite your bid for Supply, Installation, Commissioning and Maintenance of Server, Storage & related Equipments for GIS based Application on behalf of Bhaskaracharya Institute for Space Applications and Geo-Informatics (BISAG), Gandhinagar.

The selected agency will have to Supply, Install, Commissioning and Maintain the supplied Server, Storage & related Equipments as per the scope defined in this bid for the contract period.

Gujarat Informatics Limited, on behalf of Bhaskaracharya Institute for Space Applications and Geo-Informatics (BISAG), Gandhinagar has published this bid for ***“for Supply, Installation, Commissioning and Maintenance of Server, Storage & related Equipments for GIS based Application on behalf of Bhaskaracharya Institute for Space Applications and Geo-Informatics (BISAG), Gandhinagar”***. GIL invites your bid for the same.

Proposal in the form of BID are requested for the items/services in complete accordance with the documents to be uploaded as per following guidelines.

Bidder shall submit their bids on <https://www.gil.nprocure.com>.

The bidder will have to submit **Nonrefundable Bid Processing Fees of Rs. 17,700/- & Earnest Money Deposit (E.M.D.) of Rs. 8,00,000/- (Refundable)** on or before date & hours of submission of bid in a sealed cover at GIL office with the heading ***“Bid processing Fees & EMD for E-tender no HWT140818506 for Supply, Installation, Commissioning and Maintenance of Server, Storage & related Equipments for GIS based Application on behalf of Bhaskaracharya Institute for Space Applications and Geo-Informatics (BISAG), Gandhinagar.”***

- **Bid processing fees** must be in the form of **Demand Draft** in the name of **“Gujarat Informatics Ltd.”** payable at Gandhinagar along with the covering letter.
- **EMD** as mentioned above, shall be submitted in the form of Demand Draft **OR** in the form of an unconditional Bank Guarantee (**which should be valid for 6 months from the last date of bid submission**) of any Nationalized Bank including the public sector bank or Private Sector Banks or Commercial Banks or Co-Operative Banks and Rural Banks (operating in India having branch at Ahmedabad/ Gandhinagar) as per the G.R. no. EMD/10/2018/18/DMO dated 16.04.2018 (http://www.gil.gujarat.gov.in/grs/DMO_2173_16_Apr_2018_714.pdf) issued by Finance Department or further instruction issued by Finance department time to time; in the name of **“Gujarat Informatics Ltd.”** payable at Gandhinagar (as per prescribed format given at Annexure A) and must be submitted along with the covering letter.

Please affix the stamp of your company on the overleaf of demand draft.

Note: Failing to submit physical covers of EMD and Bid Processing Fees at GIL on or before the last date & time of submission as given in this bid, may lead to the rejection of the bid.

The Bid Processing Fees & EMD Section and Eligibility Section will be opened on the specified date & time in the presence of the committee members and representatives of the bidders who choose to attend. The representative will be held responsible for all commitments made on behalf of the bidder and that will be considered valid for all further dealings related to this tender process.

Once quoted, the bidder shall not make any subsequent price changes, whether resulting or arising out of any technical/commercial clarifications sought regarding the bid, even if any deviation or exclusion may be specifically stated in the bid. Such price changes shall render the bid liable for rejection.

In addition to this bid, the following sections uploaded are part of Bid Documents.

Section	Name of Section	Page No.
Section - 1	Eligibility Criteria	5
Section - 2	Scope of Work	6
Section - 3	Instructions to Bidders / General Terms & Conditions	9
Section - 4	Technical Specifications of Equipments	15
Section - 5	Financial Bid Format	20
Section - 6	Annexure	22
Section - 7	Performa of Compliance letter / Authenticity of Information Provided	24
Section - 8	Performa of Performance Bank Guarantee & Contract Form	28

The summary of various activities with regard to this invitation of bids are listed in the table below:

1	Bid Reference Number	Tender No. HWT140818506
2	Date of Pre-Bid Meeting	24.08.2018 on 1500 hours
3	Venue of Pre-Bid Meeting	Bhaskaracharya Institute for Space Application & Geo-informatics (BISAG) Near Ch-0 Circle, Indulal Yagnik Marg, Gandhinagar- 382 007
4	Last Date & Time for Submission of Bids electronically on https://www.gil.nprocure.com	06.09.2018 till 1500 hours
5	Date & Time of Opening of Bids (Un-priced Bids)	06.09.2018 at 1700 hours
6	Date & Time of Opening of Commercial Stage	Will be intimated to the qualified bidders at a later date.
7	Venue of Opening of Bids	Gujarat Informatics Limited Block No. 1, 8 th Floor, Udyog Bhavan, Sector-11, Gandhinagar 382 010
8	Bid Processing Fees (Non-refundable)	Rs. 17,700/- (Rupees Seventeen Thousand Seven Hundred Only)
9	Earnest Money Deposit (E.M.D.)	Rs. 8,00,000/- (Rupees Eight Lacs Only)
10	GIL Contact Person	DGM (Tech.), GIL

Note: Please specify Tender Number in all your correspondence.

SECTION I

Eligibility Criteria for the bidder:

1. The bidder should have a total sum of turnover of Rs. 15 Crore (Minimum) in the last three financial years as on 31st March 2018. The copies of Audited Annual Accounts/Balance Sheet along with Profit & Loss Account and CA Certified Statement for last three financial years as on 31st March 2018 shall be attached along with the bid. **For the Year 2017-18 if audited accounts are not available then CA certificate can be submitted (Form no. E-1)**
2. The bidder must have one office in Gujarat. Please attach the copies of any two of the following: Property Tax Bill of last year / Electricity Bills of last one year / Telephone Bills of last one year / VAT Registration / CST Registration / Valid Lease Agreement. **(Form no. E-2). In case, bidder does not have office in Gujarat, bidder should give undertaking to open office in Gujarat within 45 days from the date of purchase order.**
3. Bidder must ensure that the warranty support & service should be available up to delivery locations to provide repairing cum replacement services of faulty equipments within 24 hrs. Bidder is required to provide the name & address & contact details of the firm for providing warranty support & repairing cum replacement service up to delivery locations. **(Form no. E-3)**
4. Bidder must have experience of supply, installation & maintenance of Server, Storage and Data Centre related equipments. Bidder should have received and executed at least 2 work orders of above mentioned work of minimum value of Rs. 1 Crore each in **last 3 years**. Customer references & Purchase orders must be attached along with the bid. **(Form no. E-4)**
5. The bidder should be authorized by its OEM (for the offered Server & Storage & other Equipments) to quote this bid **(Form no. E-5)**. The bidder should have a back-to-back support agreement/arrangement for services including supply of spare parts etc. with the Original Equipment Manufacturer (OEMs). Please attach the copy of Authorization on OEM letter head and signed by authorized signatory for the item(s) to be offered in this bid.
6. The Manufacturer of the product (OEM) should be ISO 9001:2008 Process Certified for manufacturing **(Form no. E-6)**. Valid ISO Certificates to be submitted along with the bid.
7. Bidder should not be blacklisted by any Ministry of Government of India or by any State Government of India or any of the Government PSUs at the time of bidding. Self-Declaration / Certificate / affidavit mentioning that the Bidder is not blacklisted as per the clause should be submitted.
8. No consortium will be allowed. The bidder must meet all the eligibility criteria by self. Bidders undertaking should be submitted.
9. OEM for Server & Storage should be in the Leadership / Challengers / Visionaries quadrant in the latest available Gartner Magic Quadrant (Magic Quadrant for Modular Servers & General Purpose Disk Arrays) OR should be among the top Five positions in terms of worldwide market share as per latest available IDC report. Documentary proof to be submitted for the same.

Note:

1. All the details and the supportive documents for the above mentioned items should be uploaded in eligibility section in the bid.
2. Bidders who wish to participate in this bid will have to register on <https://gil.nprocure.com>. Further bidders who wish to participate in online bids will have to procure Digital Certificate as per Information Technology Act 2000 using which they can sign their electronic bids. Bidders can procure the same from (n) code solutions – a division of GNFC Ltd., or any other agency licensed by Controller of Certifying Authority, Govt. of India. Bidders who already have a valid Digital Certificate need not procure a new Digital Certificate.

SECTION II

Scope of Work

Bidder is required to Supply, Install, Testing, Commissioning and Maintenance (for the contract period of 5 years) of Server, Storage & related Equipments (with necessary software & licenses) and Integration with existing BISAG Setup for the required Solution Architecture for GIS based Application at BISAG, as per the specifications mentioned in the Bid document. Complete System should be Integrated with existing BISAG Setup.

The bidder shall be responsible for implementation of the work as defined in the bid document. Bidders also have to provide training to BISAG persons for the equipments to be supply under this bid.

Unit cost is required to be offered for all the items as requested. GIL/GoG does not guarantee any fixed quantity of any item as mentioned in bid, at the time of awarding the order. The quantity of any item may vary depending upon the change in the requirements/grants available with the purchaser(s), which shall be binding to the bidder. The rates should be valid for a period of 180 days from the date of financial bid opening.

All goods or materials shall be supplied strictly in accordance with the specifications, drawings, datasheets, other documents and conditions stated in the Bid / Work order. All materials supplied by the Bidder shall be guaranteed to be of the best quality of their respective kinds and shall be free from faulty design, workmanship and materials.

Documents: The Bidder shall provide 1 set of documents and manuals along with related software & their updates for the items they supply at the time of delivery (hard copy, soft copy with each item of the unit supplied.)

Installation & Training: Onsite training is to be given by the Bidder to BISAG persons for the equipments to be supply, on operation and troubleshooting during the time of supply.

GENERAL:

- a. The bidder should produce letter of authorization for the items to be quoted from their respective OEMs.
- b. It will be joint responsibility of the bidder & OEM to ensure after-sale support and warranty for all component/ equipment.
- c. Any substandard equipment included in the offer may cause rejection of the complete offer with the sole responsibility of bidder.
- d. Bidder should include required components like LAN Switch, PDU, Cable, Connector etc. for integration with existing BISAG Setup.
- e. The bidder will have to carry out the complete LAN work & Fiber cabling installation work (including laying, HDPE pipe, PVC pipe, Cable Tray, Duct across floors/campus/building) with Casing Caping as per the requirements considering the industry standard practice. Necessary Fiber Cable, LAN Cable, Patch Cords etc. to be consider by bidder to meet the requirements as defined in the scope of work.
- f. Necessary Labelling and Dressing to be done for LAN & Fiber cables. Fixing, Splicing & OTDR test with report to be done for Fiber Cable at a time completion of installation work. The necessary document to be submitted along with final installation report.
- g. The bidder will have to connect the two sites i.e. Site A and Site B (within same campus) using 6 Core OM4 MM Fiber cable with 2 Separate routes in consultation with BISAG. However, at a time of awarding of purchase order bidder has to provide estimated bill of material for passive components.
- h. Bidder should include any other components like software updates, software licenses, pertaining to Hardware items including Storage System if needed for integration with existing BISAG System. The bidder has to provide updates / up-gradation of all the software free of charges during the validity of support contract.

- i. The bidder should ensure that the offered system is not an “end of life” product and the necessary spare component is available for next 3 Years after the completion of the warranty/guarantee period.
- j. The proposed equipment’s (like Server, Storage, SAN Switch & Network Switch) should not be declared End-of-Production for next 2 years and End-of-Support for next 5 years from the date of end of sale.
- k. The successful bidder will have to supply set of printed technical, user and installation manual and connectivity schematic with respect to equipment and whole solution.
- l. Each of the items of this bid must have to be quoted with 5 years of back to back OEM comprehensive OEM warranty.
- m. The delivery period should be within 6 weeks from the date of placement of purchase order. Installation, Configuration & Integration with existing BISAG Infrastructure to be complete within 2 weeks from the go ahead given by BISAG after delivery of the material. This also includes on-site training and on site-support.
- n. The bidder has to offer Operation and Maintenance Training to Engineers or other concern persons recommended by BISAG, Gandhinagar at the installation site immediately after completion of installation. The training should include the troubleshooting of the equipments delivered.
- o. The bidder will have to provide onsite service, support and warranty of the supplied equipments for the warranty period of 5 years from the date of successful completion of FAT (Final Acceptance Test).
- p. Bidder may advice to visit to BISAG for further clarification and technical discussion if any before pre-bid meeting.
- q. The bidder has to offer trainings as given below:
 - i. **Operation & Maintenance Training:** The bidder has to offer Operation and Maintenance Training to Engineers or other concern persons recommended by BISAG, Gandhinagar at the installation site immediately after completion of installation.
 - a. The successful bidder is responsible for complete knowledge transfer, Operating Manuals, SOP’s including, but not limited to:
 - i. Installation and configuration details of solution deployed by the bidder
 - ii. Contact details of OEM and bidder representative for warranty and OEM support.
 - iii. Any other details that may be required/asked by BISAG
 - ii. **On-site Support:** The bidder should offer on-site support for 7 days immediately after commissioning and as and when required during the warrantee period of 5 years.

r. MIS Reports

The bidder shall ensure that the system is able to provide following reports and would require to configure the same at the time of installation.

Sr. No.	Types of Reports	Periodicity
1	<ul style="list-style-type: none"> • System performance report which includes utilization/available CPU, memory, Cache, disks, etc. • All type of event reports • Backup status reports • SLA Compliance report • Reports as directed by the State for SLA calculation • Summary of system reboot • Summary of issues / complaints logged with the OEMs. • Patch update status as notified by the OEM 	Weekly, Monthly, Quarterly

2	<ul style="list-style-type: none"> Log of preventive / scheduled maintenance undertaken Details of Patch, updates, Vulnerability fixes released and implementation status of same Details of break-fix maintenance undertaken 	Monthly, Quarterly
3	<ul style="list-style-type: none"> Any other report 	As and when required

The indicative of required Solution Architecture is as below:

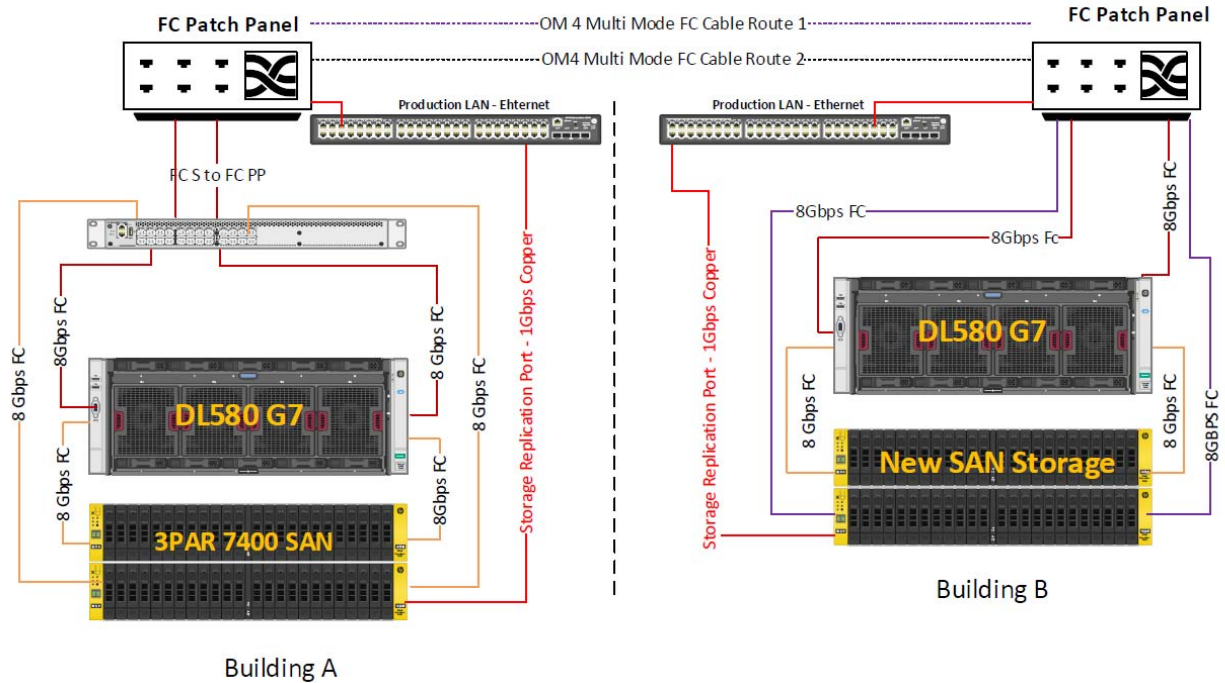

- Site A and Site B will be in same campus.
- Site A and Site B will be connected through OM4 MM Fiber cable with 2 Separate routes. The approximate fiber laying distance will be around 500 Mtrs.
- FC Patch Panel will be deployed at both the locations.
- Primarily 24 Port FC SAN Switch to be deploy at Site A. Site B will be connected to SAN Switch through FC Patch Panel.
- Server is directly connected to Local SAN Storage.
- Both the location Servers will access both the SAN Storage as and when required.
- Existing Storage of Site A will be connected to Storage of Site B with Sync or Async replication with 1 Gbps connectivity as per requirement in consultation with BISAG.

SECTION III

Instructions to the Bidders / General Terms & Conditions

1. The last date of submission of bid on the website <https://gil.nprocure.com> is **06.09.2018 up to 1500 Hrs.** No physical bids will be accepted under normal circumstances. However, GIL reserves the right to ask the bidders to submit the bid and/or any other documents in physical form.
2. The bid is non-transferable.
3. **The Bidder may quote only one option (i.e. only one product can be quoted) against each item.** Bidders are required to mention make & model of the product. (Do not write “OEM” against items as bidders are expected to give make & model of the product).
4. The successful bidder will have to Supply, Install, Commissioning and Maintain and provide operational training for supplied hardware and peripherals and to configuration / reconfiguration as per the scope of work and to carry out necessary integration with existing BISAG Infrastructure.
5. If in any case the quoted Item is not available in the market, the bidder will have to supply Higher Version/replacement of that Item in the quoted cost in the same time duration with prior approval of GIL/Purchaser. No “End of Life / End of Support” product should be quoted to minimize such instances. (Make & Model quoted by the bidder should be available till the bid validity, duly supported for spares/OEM support for warranty period).
6. The Bidder shall bear all the costs associated with the preparation and submission of its bid, and GIL in no case will be responsible or liable for these costs, regardless of conduct or outcome of bidding process.
7. Technical specifications indicated are minimum specification. Bidder may quote for better solution. The bidder should provide following with the technical bid:
 - Make & Model Number
 - Name of Manufacturer
 - Technical Literature
 - Manufacturer’s Data Sheet
 - Compliance statement from the OEM of the product
8. The bidder has to upload the compliance letter on its letter head duly signed by the authorized signature & other supporting documents as asked for in the bid in scanned format. Failing to submit the same or non-compliance / deviation from any bid terms and conditions, eligibility criteria or technical specifications may result in rejection of the bid.
9. The Bidder has to examine all instructions, forms, terms, conditions and specifications in the bidding documents. Failure to furnish all information required by the bidding documents or submission of a bid not substantially responsive to the bidding documents in every respect will be at the Bidder’s risk and may result in rejection of its bid.
10. Amendment of Bidding Documents (Corrigendum)
 - 10.1. At any time prior to the deadline for submission of bids, GIL may, for any reason, whether its own initiative or in response to the clarification request by a prospective bidder, modify the bidding documents.
 - 10.2. The corrigendum will be published on website <https://gil.nprocure.com> & www.gil.gujarat.gov.in.
 - 10.3. In order to allow prospective bidders reasonable time to take into consideration the amendments while preparing their bids GIL, at its discretion, may extend the deadline for the submission of bids.
11. Bid Currency - Prices shall be quoted in Indian Rupees only. Payment for the supply of equipments as specified in the agreement shall be made in Indian Rupees only.
12. The bidder will have to submit **Bid Processing Fees (Nonrefundable) of Rs. 17,700/- & Earnest Money Deposit (E.M.D.) of Rs. 8,00,000/- (Rupees Eight Lacs Only) (Refundable)** on or before date & hours of submission of bid in a sealed cover at GIL office with the heading “**Bid processing Fees & EMD for E-**

tender no HWT140818506 for Supply, Installation, Commissioning & Maintenance of Servers, Storage & related Equipments for GIS based Application on behalf of BISAG, Gandhinagar.

- Bid processing fees must be in the form of Demand Draft in the name of “Gujarat Informatics Ltd.” payable at Gandhinagar along with the covering letter.
- EMD as mentioned above, shall be submitted in the form of Demand Draft **OR** in the form of an unconditional Bank Guarantee (which should be valid for 6 months from the last date of bid submission) of any Nationalized Bank including the public sector bank or Private Sector Banks or Commercial Banks or Co-Operative Banks and Rural Banks (operating in India having branch at Ahmedabad/ Gandhinagar) as per the G.R. no. EMD/10/2018/18/DMO dated 16.04.2018 (http://www.gil.gujarat.gov.in/grs/DMO_2173_16_Apr_2018_714.pdf) issued by Finance Department or further instruction issued by Finance department time to time; in the name of “Gujarat Informatics Ltd.” payable at Gandhinagar (as per prescribed format given at Annexure A) and must be submitted along with the covering letter.

Please affix the stamp of your company on the overleaf of demand draft.

Note: Failing to submit physical covers of EMD and bid processing fees at GIL on or before last date of bid submission date & time may lead to the rejection of the bid.

13. In case of non-receipt of Bid processing fees & EMD as mentioned above in your bid will be rejected by GIL as non-responsive.
14. Unsuccessful bidder's E.M.D. will be returned as promptly as possible after the expiration of the period of bid validity OR upon the successful Bidder signing the Contract, and furnishing the Performance Bank Guarantee as prescribed by GIL, whichever is earlier.
15. In exceptional circumstances, GIL may solicit the Bidder's consent to an extension of the period of validity. The request and the responses thereto shall be made in writing. Bidder may refuse the request without forfeiting its E.M.D. A Bidder granting the request will not be permitted to modify its bid.
16. The Successful bidder has to submit Performance Bank Guarantee @ 10 % of total order value within 15 days from the date of issue of Purchase order **for the duration of contract period + extra 3 months** from any Nationalized Bank including the public sector bank or Private Sector Banks or Commercial Banks or Co-Operative Banks and Rural Banks (operating in India having branch at Ahmedabad / Gandhinagar) as per the G.R. no. EMD/10/2018/18/DMO dated 16.04.2018 (http://www.gil.gujarat.gov.in/grs/DMO_2173_16_Apr_2018_714.pdf) issued by Finance Department or further instruction issued by Finance department time to time. (The draft of Performance Bank Guarantee is attached herewith).
17. Successful Bidder will have to sign the contract upon receiving the confirmed purchase order with the purchaser(s) within 15 working days from the date of confirmed purchase order. (The draft is attached herewith).
18. The successful Bidder's E.M.D. will be returned upon the Bidder signing the Contract, and furnishing the Performance Bank Guarantee @ 10% of the total order value and offer of inspection of the ordered material.
19. The E.M.D. may be forfeited at the discretion of GoG / GIL, on account of one or more of the following reasons:
 - (a) If a Bidder withdraws its bid during the period of bid validity.
 - (b) If Bidder does not respond to requests for clarification of their Bid
 - (c) If Bidder fails to co-operate in the Bid evaluation process, and
 - (d) In case of a successful Bidder, if the Bidder fails:
 - (i) To sign the Contract as mentioned above or
 - (ii) To furnish performance bank guarantee as mentioned above or
 - (iii) If the bidder is found to be involved in fraudulent practices.
20. Termination for Default:
 - 20.1. The Purchaser may, without prejudice to any other remedy for breach of contract, by written notice of default sent to the Bidder. Bidder will be given notice/cure period of 30 days, after that purchaser will terminate the Contract in whole or part after:

- a) If the bidder fails to deliver any or all of the Goods as per the delivery schedule mentioned in the bid, or within any extension thereof granted by the Purchaser or
- b) If the Bidder fails to perform any other obligation(s) under the Contract/Purchase order.
- c) If the Bidder, in the judgment of the Purchaser has engaged in corrupt or fraudulent practices in competing for or in executing the Contract.

For the purpose of this clause:

“Corrupt practice” means the offering, giving, receiving or soliciting of anything of value of influence the action of a public official in the procurement process or in contract execution.

“Fraudulent practice: a misrepresentation of facts in order to influence a procurement process or the execution of a contract to the detriment of the purchaser, and includes collusive practice among Bidders (prior to or after bid submission) designed to establish bid prices at artificial non-competitive levels and to deprive the purchaser of the benefits of free and open competition;”

- 20.2. In the event the Purchaser terminates the Contract in whole or in part, pursuant to Clause 20.1 above, the Purchaser may procure, upon such terms and in such manner, as it deems appropriate, Goods or Services similar to those undelivered, and the Bidder shall be liable to the Purchaser for any excess costs for such similar Goods or Services. However, the Bidder shall continue the performance of the contract to the extent not terminated.
21. If the successful bidder fails to submit the Performance Bank Guarantee & sign the Contract Form within prescribed time limit, the EMD of the successful bidder will be forfeited. GIL also reserves the right to blacklist such bidder from participating in future tenders if sufficient cause exists.
22. Price shall be inclusive of all freight, forwarding, transit insurance, installation, warranty and maintenance charges.
23. Prices shall be in Indian Rupees. The prices shall strictly be submitted in the given format. Quoted prices shall be inclusive of all taxes except GST. The tax components like GST as applicable shall be mentioned separately in the respective columns.
24. Late Bids: The bidder will not be able to submit the bid after final submission date and time.
25. Modification and Withdrawal of Bids
 - 25.1. The Bidder may modify or withdraw its bid before the due date of bid submission.
 - 25.2. No bid will be allowed to be modified subsequent to the final submission of bids.
 - 25.3. No bid will be allowed to be withdrawn in the interval between the deadline for submission of bids and the expiry of the bid validity. Withdrawal of a bid during this interval will result in the forfeiture of bidder’s E.M.D.
26. Bids will be opened with the buyer’s private digital key in the presence of Bidder’s representatives, who choose to attend. The Bidder’s representatives who are present shall sign a register/attendance sheet evidencing their attendance. The representative will be held responsible for all commitments made on behalf of the bidder and that will be considered valid for all further dealings related to this bid process. In the absence of the bidder(s), the Tender Committee may choose to open the bids as per the prescribed schedule.
27. The Bidder’s names, bid modifications or withdrawals, discounts and the presence or absence of relevant E.M.D. and such other details as GIL/GoG officer(s) at their discretion, may consider appropriate, will be announced at the opening.
28. **Evaluation of the Bids:** After the closing time of submission, GIL / GoG committee will verify the submission of Bid Processing Fees & EMD as per bid terms and conditions. The eligibility criteria evaluation will be carried out of the responsive bids. The technical bids of the bidders who are complying with all the eligibility criteria will be opened and evaluated next. GIL will seek clarifications if required on eligibility & technical section. The financial bid of the technically qualified bidders will be opened and financially L1 bidder will be decided from the sum total of prices for all line items without tax with warranty and then called for further negotiations if required.

29. As per the provision in Electronics & IT/ITeS Start-up Policy Resolution No. ITS/10/2015/5284/IT dated 6th June, 2016 issued by Department of Science & Technology; in e-Governance project undertaken by Government Departments or its Boards, Corporations or parastatal bodies getting grants from the Government, the chosen solution provider or system integrator will pass on job work or will outsource part of the work of a value ranging between 5% to 10% of the contract value to the eligible start-ups and to students of shortlisted Technical Colleges in Gujarat. In such arrangements, the responsibility of meeting SLAs (Service Level Agreements) will continue to belong to the solution provider or the system integrator.
30. The bidder will have to offer the inspection in the manner as decided by GIL before delivering to the respective site or at customer sites. The cost of the same has to be borne by the supplier. Any deviation found in the specification of the produced goods from the bid specification will lead to the cancellation of the order, forfeiture of EMD/PBG and prohibition in the participation in the future purchase of Government of Gujarat. GIL/GoG will not be responsible for any time delay which may arise due to any deviation from the bid technical specification found at the time of inspection and the bidder has to deliver and install the ordered goods within prescribed time limit. At the time of inspection, bidder is required to produce OEM's confirmation on OEM's letter head for back to back warranty support as per tender terms & conditions.
31. The Indenter's right to inspect, test and, where necessary, reject the Goods after the Goods arrival at Customer Site shall in no way be limited or waived by reason of the Goods having previously been inspected, tested and passed by the Purchaser or its representative prior to the Goods shipment.
32. **Delivery:** Within **6 weeks** from the date of confirmed purchase order.
- Installation, Configuration & Integration:** Within 2 weeks from the go ahead given by the department after delivery of the material.
33. In case of successful bidder is found in breach of any condition(s) of bid or supply order/work order, at any stage during the course of supply / installation or warranty period, the legal action as per rules/laws, shall be initiated against the successful bidder and EMD/PBG shall be forfeited, besides debarring and blacklisting the bidder concerned for the time period as decided by Govt., for further dealings with GoG.
34. Bid validity will be of **180 days after the date of financial bid opening**. A bid valid for shorter period shall be rejected as non-responsive. **If required, GIL may extend the bid validity for further period from the date of expiry of bid validity in consultation with the successful bidder.**
35. Bidders are required to quote all items including optional add-ons as well. Incomplete bids will be treated as non-responsive and will be rejected.

36. Warranty

- 36.1. **Warranty:** Comprehensive onsite warranty for minimum 5 Year from the date of installation & completion of successful FAT of procured equipments.
- 36.2. If any equipment gives continuous trouble, say 3 times in one month during the warranty period, the bidder shall replace the same with new equipments without any additional cost to the purchaser.
- 36.3. If any manufacturing or other technical defects are found within the warranty period, the same will have to be replaced or rectified free of cost by the bidder.
- 36.4. Maintenance service: Free maintenance services shall be provided by the Bidder during the period of warranty.
- 36.5. In case, bidder is not providing satisfactory support & doing unwarranted delay in providing warranty support, Government offices reserves right to repair the equipment at risk & cost of the bidder.
- 36.6. The Bidder / System Integrator will be required to co-ordinate with software vendor and / or do liaisoning with other service provider to achieve the end-to-end connectivity.

37. Penalty Clause

37.1. Penalties for delay in delivery and installation:

- a) If the bidder fails to deliver and install the requisite hardware and software within 6 weeks from the issue of the confirmed purchase order, then a sum equivalent to one percent (1 %) of the total contract value shall be deducted from the payment for each calendar week of delay or part thereof.

- b) The amount of penalties for delay in delivery shall be subject to a maximum limit of 10% of the total contract value.
- c) Delay in excess of 5 weeks will be sufficient to cause for termination of the contract. In that case the Performance Bank Guarantee of the bidder will be forfeited.
- d) The successful bidder will have to carry out the Installation, Configuration & Integration within 2 weeks from the go ahead given by the department after delivery of the material. The delay in the Installation, Configuration & Integration will attract the penalty of Rs. 5,000/- per day delay in addition to any penalty for the delay in delivery.
- a) In case, the selected bidder does not supply the ordered items for any reason, he will be liable to pay the difference amount to the purchaser, over and above the Performance Guarantee, which indenter departments\Boards\Corporations have to pay to the next or other selected bidder for purpose of the said items.

37.2. Operational / Warranty period Penalties:

- a) During warranty period, bidder will have to response the call within 4 hours and resolve the complaint within 24 hours. If the complaint is not resolved within 24 hrs, the penalty of Rs. 1,000 per hour delay will be levied for Server, Storage, SAN Switch. If the complaint is not resolved within 48 hrs regarding other items like FC Panel and other supplied components, the penalty of Rs. 500 per day delay will be levied. However, if the complaints are not resolved within 7 days then from 8th day till 14th day, the penalty would be levied @ 150% and from 15th day onwards the penalty @ 200% of the above rates would be levied. The amount of penalty will be recovered from the Performance bank guarantee during warranty period.
 - b) The amount of Operational/Warranty period Penalty shall be subject to a maximum limit of 10% of the total contract value.
 - c) Successful bidder should submit the Performance Bank Guarantee @ 10% of total order value for the duration of Warranty Period + 3 months as per bid requirements. In any case, bidder is required to maintain 10% PBG at all time during the period of contract. In case of any penalty claimed from the submitted PBG during the contract period, the successful bidder is required to submit the additional PBG of the amount equal to the penalty claimed for the duration up to the validity of original Bank Guarantee. For example, "X" amount of penalty will be claimed during the 5th month of contract period, then bidder is required to submit the additional PBG of "X" amount for the period of 58 months i.e. 63 months - 5 months.
- 38. Payment:** Payment for Goods and Services shall be made by Purchasing Department in Indian Rupees as follows:
- 38.1. No advance payment will be made.
 - 38.2. 70 % payment (of Table A - as defined in Financial Bid Format) after successful inspection / physical verification & delivery of the ordered goods at specified locations. The inspection / physical verification will be done as decided by GIL/BISAG.
 - 38.3. 20 % payment (of Table A - as defined in Financial Bid Format) will be made after completion of installation, commissioning, integration & user's functional training as per the scope of work.
 - 38.4. Balance 10% payment (of Table A - as defined in Financial Bid Format) will be made after three months from the date of successful completion of FAT.
 - 38.5. AMC Cost (Table B - as defined in Financial Bid Format) of the System will be released every year in advance.
39. GIL reserves the right to change any bid condition of any item even after inviting the bids, with/without prior notification.
40. GoG / GIL's Right to accept any Bid and to reject any or all Bids – GoG / GIL reserves the right to accept or reject any bid, and to annul the bidding process and reject all bids at any time prior to awarding the Contracts, without thereby incurring any liability to the affected Bidder or bidders or any obligation to inform the affected Bidder or bidders of the grounds for such decision.
41. The bid quantities are estimated based on the receipt of the requirement from Indenting Department. The quantities may decrease up to 50% of the bid quantity or increase up to 30% of the bid quantity at

the time of finalization, depending upon the change in the requirements/grants available with the purchaser(s), which shall be binding to the bidder.

42. **Limitation of Vendor's Liability:** Vendor's cumulative liability for its obligations under the contract shall not exceed the contract value and the vendor shall not be liable for incidental, consequential, or indirect damages including loss of profit or saving.
43. All correction/addition/deletion shall require authorized countersign.
44. Force Majeure Shall mean and be limited to the following:
- Fire, explosion, cyclone, earthquake, flood, tempest, lightning or other natural physical disaster;
 - War / hostilities, revolution, acts of public enemies, blockage or embargo;
 - Any law, order, Riot or Civil commotion, proclamation, ordinance, demand or requirements of any Government or authority or representative of any such Government including restrictive trade practices or regulations;
 - Strikes, shutdowns or labor disputes which are not instigated for the purpose of avoiding obligations herein, or;
 - Restrictions imposed by the Government or other statutory bodies which prevents or delays the execution of the order;
 - Any other circumstances beyond the control of the party affected;

The BIDDER shall intimate Purchaser by a registered letter duly certified by the local statutory authorities, the beginning and end of the above causes of delay within seven (7) days of the occurrence and cessation of such Force Majeure Conditions. In the event of delay lasting over two months, if arising out of causes of Force Majeure, Purchaser reserves the right to cancel the order.

Delivery & Installation period may be extended due to circumstances relating to Force Majeure by the Purchaser. Bidder shall not claim any further extension for delivery & installation or completion of work. Purchase / GoG shall not be liable to pay extra costs under any circumstances.

The BIDDER shall categorically specify the extent of Force Majeure conditions prevalent in their works at the time of submitting their bid and whether the same have been taken in to consideration or not in their quotations. In the event of any Force Majeure cause, the BIDDER shall not be liable for delays in performing their obligations under this order and the delivery dates can be extended to the BIDDER without being subject to price reduction for delayed deliverables, as stated elsewhere.

It will be prerogative of Purchaser / GoG to take the decision on force major conditions and Purchaser decision will be binding to the bidder.

45. **The Clarifications if any should be submitted in writing to GIL at least on or before 1 days of pre-bid meeting date. Thereafter the clarifications received from the bidders will not be entertained.**

Your bid should be submitted on website <https://gil.nprocure.com> on or before **15:00 Hours, 06.09.2018**.

Proposals after due time period will not be accepted.

The Technical Bids will be opened on **06.09.2018 at 17:00 Hours at GIL, Block No. 1, 8th Floor, Udyog Bhavan**, in the presence of the committee members and representatives of the bidders, who have submitted valid bids. Only one representative from each bidder will be allowed to attend the tender opening. The representative will be held responsible for all commitments made on behalf of the bidder and that will be considered valid for all further dealings related to this tender process.

Please address all queries and correspondence to

Shri Vivek Upadhyay, DGM (Tech.),
Gujarat Informatics Limited
Block No. 1, 8th Floor, Udyog Bhavan, Gandhinagar - 382010
Phone No. 079-23259239, Fax No. 079-23238925,
E-mail: viveku@gujarat.gov.in; vijayb@gujarat.gov.in

Fax / Email should be followed by post confirmation copy.

SECTION IV

Minimum Technical Specification

Sr. No.	Item Minimum Specifications		Matched/ Not Matched	Remarks (If any)
Item No. 1: Rack based Server				
1	Parameter	Functionality		
	Chassis	2U Rack Mountable		
	CPU	Intel® Xeon® Silver 4114 Processor (2.20GHz, 10 Core) Processor or higher.		
	Motherboard	Latest compatible Intel Chipset on Intel or equivalent OEM motherboard for above CPU		
	Slots	Should support minimum 2 numbers of PCIe slots		
	Memory	Minimum 256 GB DDR4-2666 Registered (RDIMM) memory		
	Memory Protection	Advanced ECC, Online Spare, Mirrored Memory		
	HDD for OS	8 x 1.8 TB SAS 10K RPM		
	RAID Controller	RAID controller for RAID 0, RAID 1, RAID 5 and RAID 10 configurations with 2GB cache memory		
	Network Controller	2 * 10 Gbps BASE T Ethernet ports & 4 * 1 Gbps Base T Ethernet ports		
	Fiber Channel HBA	One 2x16Gbps FC HBA for Storage Connectivity		
	Graphic / Video Memory	Integrated Graphic with external VGA port		
	Ports	Minimum 2 USB ports (with Min 1 USB 3.0 port)		
	Driver / Software Utility	Server OEM's System Management utilities with all required device driver software as per above configuration for OS Installation, System Configuration and for server management.		
	Redundancy	No single point of failure for Disks, Cache memory, I/O Ports, Power Supply, Fan etc.		
	System Management	1 Remote Management Port (TCP/IP based)		
	Operating System	Windows Server 2016 Standard Edition		
	OS Support	Microsoft Windows Server, Linux, VMWare ESXi		
Certifications	RoHS, UL, CE/FCC or equivalent third party certification from reputed Agency, Windows Certification			
Others	Should be supplied with Indian standard Power cables and all other required accessories like patch cords, connectors, interfaces, licenses etc.			
Warranty	5 Years Comprehensive Onsite Warranty			

Sr. No.	Item Minimum Specifications	Matched/ Not Matched	Remarks (If any)
Item No. 2: Storage System			
2	Parameter	Specification	
	Capacity	<ul style="list-style-type: none"> • Total Usable capacity should be 500 TB from Day one. • The Storage capacity mentioned is the Usable capacity in RAID 6 Configuration. • Disks should be minimum of 10K or higher RPM with 6TB SAS drives • Should have at least 2 Boot SSD / Flash drives to run and protect the OS and storage system metadata. • Proposed solution should have minimum 10 Gbps throughput. 	
	High Availability	<ul style="list-style-type: none"> • Controllers should work in Active-Active mode from day one. • The storage should not have any single point of failure on components like controllers, disks, cache memory, I/O Ports, Power supply, Fan, etc. • Should have self-healing design to protect against disk or controller failure. 	
	Cache	<ul style="list-style-type: none"> • Each storage Controller should be supplied with minimum 64 GB Cache and scalable up to 128 GB. • The storage array must have complete cache protection mechanism either by de-staging data to disk or providing complete cache data protection with battery backup for minimum 4 hours. • Reclaiming of Cache utilization (manual and automatic) by De-provisioning/removal of capacity. 	
	Compatibility	<ul style="list-style-type: none"> • Should support SAS/NL-SAS drives within same storage system • Should support Windows and Linux operating systems. • Modular design to support controllers and disk drives expansion • Should be Rack Mountable • should support remote management 	
	RAID	<ul style="list-style-type: none"> • The solution must support different RAID groups (RAID 0, 1, 5, 6 and 10) 	
	Storage management software	<ul style="list-style-type: none"> • Licenses for the storage management software should include disc capacity/count of the complete solution and any additional disks to be plugged in the future, up to max capacity of the existing controller/units. 	

Management Console	<ul style="list-style-type: none"> • A single command console for entire storage system. • The Solution should allow role-based access for auditing, monitoring and other general operations and administration capabilities through GUI/CLI • Minimum features of Management software should be: <ul style="list-style-type: none"> ▪ System status i.e. CPU, Memory, Disks, Network resources, Cache, etc ▪ Display total, allocated and utilized capacity ▪ Role based user access management, disk quota management, user groups ▪ Dynamic allocation of disk quota ▪ Backup and Restore, ▪ Firmware upgrade ▪ Hardware details of drives, controller, connectivity, ports, etc. ▪ Overall status of compaction of data ▪ System audit Logs ▪ Should generate alert/notification ▪ Reports – Scheduled and Manual ▪ Historical graphs of storage utilization • Should display Reports like capacity utilization, RAID, Alarms, event and notifications as defined under the MIS report section of this RFP. 		
Monitoring	<ul style="list-style-type: none"> • It should have the functionality of performance, utilization monitoring of storage, disk drives and management software • Auto Alerts on Failure of physical components like CPU, Disk, Memory etc. • Should support real time monitoring of software version, hardware status and system capacity usage. 		
Network Ports	<ul style="list-style-type: none"> • Minimum 4 x 16Gb FC, 4 x 10Gbps ISCSI and 4 x 10Gbps IP (Ports for file operations) host ports for connectivity to servers. 		
Connectivity & Protocols	<ul style="list-style-type: none"> • HTTP, FTP, SFTP, NFS, CIFS/SMB, FC, iSCSI, NDMP • SNMP, ICMP, NTP, IPv4, IPv6 		
Compatibility	<ul style="list-style-type: none"> • Offered storage shall provide Synchronous and Asynchronous Replication features with Existing BISAG SAN Storage. Any additional Hardware or Software Licenses to be consider if required for the same. • Bidder should provide undertaking for the integration and operational compatibility with existing setup. 		
Others	<ul style="list-style-type: none"> • The proposed solution should be supplied with required SAN Switch, cables, Indian standard power cords and all other required accessories like patch cords, connectors, interfaces, licenses etc. 		

Note: Currently bidder will have to consider the BoQ only for the current capacity (500 TB Usable Capacity & 64 GB Cache) as asked in the specifications and quote the cost accordingly. No upfront cost to be consider for the scalability.

Sr. No.	Item Minimum Specifications	Matched/ Not Matched	Remarks (If any)
Item No. 3: 24 Port L2 Switch			
3	Layer 2 Switch with minimum 24x1G port, 2x1G with SFP and 2x10G ports (Duplex: Full, Half)		
	Should have minimum switching capacity of 40 Gbps		
	Should be IPv4 and IPv6 ready from day one		
	Should support minimum 4000 MAC address entries		
	Should support protocols like MSTP, STP, RSTP, dot1q VLAN-tagging, LACP, NTP		
	Should have features like port-security, auto-negotiate, flow control, MAC filtering		
	Should have a dedicated OOB Management port using CLI(SSH) / WebUI (SSL), SNMP (V1, V2, V3), TFTP, etc.		
	Switch should support AAA features using TACACS+, Radius / LDAP, etc.		
	All necessary SFP's, interfaces, connectors, patch cords (if any) & licenses must be delivered along with the switch from day one.		
	The Switch should be Rack mountable & the switch should be supplied with Indian standard AC power cord.		

Item No. 4: - 42U Network cum Server Rack (with all accessories)			
Sr. No.	Item	Matched/ Not Matched	Remarks (If any)
4	42U Rack (Rack Dimension: 800W *1200D)		
	Door Steel Full Perf 800W x 42U, Dual front, Dual rear		
	Fan housing unit 4 fan position		
	4 x Fan 230 Vac 90 CFM		
	Castor with ft break (2+2)		
	Captive Mounting Hardware of 20		
	3 x Shelf Stationery 725mmD		
	Sliding Tray		
	Should have sufficient perforation for ventilation of air		
	Necessary Cable Manager		
	ROHS complied		
	Necessary PDU to be provided according to the Server, Storage, SAN Switch, LAN Switch port type and power consumption.		

Sr. No.	Item Minimum Specifications	Matched/ Not Matched	Remarks (If any)
Item No. 5 & 6 : Passive Fiber Components (Including supply, installation, laying, digging, mounting, splicing, OTDR testing Labelling & Dressing etc. as per requirements.			
5	24 Port Rack Mount FC Patch Panel / LIU. Loaded with adapter plate with LC/LC MM Quad Adaptor, Alignment Sleeve, Snap Mount. LC Pigtail, MM, 50/125, Metal, 900 microns. 24F Splice Holder (if required)		
6	6 core outdoor armoured 50/125 Multimode, OM4 – UniTube (in Mtrs) Required HDPE / PVC Conduit pipe (ISI standard) to be supplied for cabling between Building A & Building B as per actual requirements.		

Sr. No.	Item Minimum Specifications	Matched/ Not Matched	Remarks (If any)
Item No. 7: 24 Port Cat 6 UTP Shuttered Patch Panel (Including supply, installation, laying, mounting, Casing Capping, Labelling & Dressing etc. as per requirements.			
7	Port Patch Panel With Rack Mount: 24 Ports Cat6, all 24 ports Fully loaded I/Os Individually replaceable, Built-in Shutter.		
	Compatible with 23 - 24 AWG solid Conductor UTP cable.		
	Should conform or exceed the EIA/TIA 568 B.2-1 standards for CAT6.		
	Metallic high strength and 1RU height, Should have routing rings, ties, labeling strips for identification.		
	Should have protection on each port to protect from dust ingress and such particles by having shutter or cap.		
	UL / ETL Verified		

SECTION V

FINANCIAL BID FORMAT

Table A

Sr. No.	ITEM	Qty. (In Nos.)	Unit Price (In Rs. Without tax)	Total Price (In Rs. Without tax)	Rate of GST (%)
A	B	C	D	E = C*D	F
1	Rack based Server	1			
2	Storage System	1			
3	24 Port L2 Switch	2			
4	42U Network cum Server Rack (with all accessories)	1			
5	24 Port Rack Mount FC Patch Panel / LIU Loaded with adapter plate (with Multi Mode Adapters)	2			
6	6 Core Outdoor Multi-Mode OM4 OFC Cable (in Mtrs)	500 *			
7	24 Port Cat 6 UTP Shuttered Patch Panel	1			
Total of Table A					

TABLE B

Sr. No.	ITEM	Price (In Rs. Without tax)	Rate of GST (%)
A	B	D	F
1	1st Year AMC of System defined in Table A		
2	2 nd Year AMC of System defined in Table A		
3	3 rd Year AMC of System defined in Table A		
4	4 th Year AMC of System defined in Table A		
5	5 th Year AMC of System defined in Table A		
Total of Table B			

Grad Total (Total of Table A + Total of Table B) (In Rs. Without tax)	
------------------------------------------------------------------------------	--

Note:

- **L1 will be the lowest sum total of rates of all line items without tax i.e. Grand Total (Total of Table A + Total of Table B).**
- *** The above mentioned quantity of the item is estimated and for evaluation purpose only. However, at the time of billing, the actual quantity will be considered based on the actual requirements.**
- **The Bidder shall explicitly mention the applicable rate of tax.**
- **Supply, installation, integration & services mentioned in scope of work should be carried out by the successful bidder at BISAG, Gandhinagar.**
- **For Passive Fiber Components, the successful bidder will have to carry out supply, installation, laying, digging, mounting, splicing, OTDR testing Labelling & Dressing etc. as per requirements. Necessary cost to be consider by the bidder.**
- **For Passive LAN Components, the successful bidder will have to carry out supply, installation, laying, mounting, Casing Caping, Labelling & Dressing etc. as per requirements. Necessary cost to be consider by the bidder.**
- **Bidder will have to consider all the necessary additional hardware, software / licenses for the mentioned activities to achieve the requirements as defined in scope of the work for the integration with the existing infrastructure of BISAG.**
- **The costs must be valid for a period of 180 days from the date of financial bid opening. It should be quoted in Indian rupees only.**
- **Costs must include cost of delivery at designated locations including transit insurance.**
- **Bidder may visit BISAG with prior appointment and may undertake the survey for more information regarding the existing infrastructure with which the proposed equipments required to be integrated before pre-bid meeting and quoting the bid.**

SECTION VI

Bid Processing Fees & Earnest Money Deposit Details

Sr. No.	Item	Amount (In Rs.)	Name of the Bank & Branch	Demand Draft No.
1	Bid Processing Fees			
2	Earnest Money Deposit (E.M.D.)			

ELIGIBILITY CRITERIA

Form No. E1: Financial strength of the bidder

Financial Year	Turnover (Rs. In Crores)	Audited Accounts uploaded? (Yes/No)
2015-16		
2016-17		
2017-18		
Grand Total		

Note: Please fill this form and upload the Audited Annual Accounts / Balance Sheet along with Profit & Loss Account and CA Certificate for the last three financial years.

Form No. E2: Office in GUJARAT

Sr. No.	Address	Contact Person	Contact Nos.	Type of supporting document attached
1				
2				

Note: You may mention more than one office (if applicable) by adding multiple rows which may be added by "NUMBER OF ROWS TO ADD".

Form No. E3: Warranty Support & repairing cum replacement service up to delivery locations

Sr. No.	Address	Contact Person	Contact Nos.	Type of supporting document attached
1				
2				
.				

Note: Please fill this form and upload the supporting documents.

Form No. E4: Experience Details for Servers, Storage and Data Centre related equipments (Customer References)

Sr. No.	Name of the Organization	Contact Person Name	Contact Details	Date of PO	Value of Order	Description of Works Carried Out	Type of Supporting Document Attached
1							
2							
.							

Note: Please fill this form and submit the supporting documents for each customer reference in scanned format. Failing the same may lead to the rejection of the bid. You may add the customer references by adding multiple rows which may be added by "NUMBER OF ROWS TO ADD".

Form No. E5: Authorization Letters

Sr. No.	Item	Make & Model	Name of OEM	Authorization letter Submitted? (Yes/No)
1	Rack based Server			
2	Storage System			
3	24 Port L2 Switch			
4	42U Network cum Server Rack			
5	24 Port Rack Mount FC Patch Panel / LIU			
6	6 Core Outdoor Multi-Mode OM4 OFC Cable			
7	24 Port Cat 6 UTP Shuttered Patch Panel			

Note: Please fill this form and upload the OEM Authorization Letter in scanned format.

Form No. E6: ISO 9001:2008 Certification for Manufacturing

Sr. No.	Item	Make & Model	Name of OEM	ISO Certificate Valid up to	ISO Certificate Submitted? (Yes/No)
1	Rack based Server				
2	Storage System				
3	24 Port L2 Switch				
4	42U Network cum Server Rack				
5	24 Port Rack Mount FC Patch Panel / LIU				
6	6 Core Outdoor Multi-Mode OM4 OFC Cable				
7	24 Port Cat 6 UTP Shuttered Patch Panel				

Note: Please fill this form and upload the ISO Certificates in scanned format.

Note: You may quote only one option against any item.

SECTION VII

Performa of Compliance letter/Authenticity of Information Provided

(On Non judicial Stamp paper of Rs. 100/- duly attested by the First class Magistrate/Notary Public)

Date:

To,
DGM (Tech.)
Gujarat Informatics Ltd.
Block-1, 8th Floor, Udyog Bhavan,
Gandhinagar

Sub: Compliance with the tender terms and conditions, specifications and Eligibility Criteria

Ref: Bid for Supply, Installation, Commissioning and Maintenance of Server, Storage & related Equipments for GIS based Application on behalf of Bhaskaracharya Institute for Space Applications and Geo-Informatics (BISAG), Gandhinagar (Tender No. HWT140818506).

Dear Sir,

With reference to above referred tender, I, undersigned <<Name of Signatory>>, in the capacity of <<Designation of Signatory>>, is authorized to give the undertaking on behalf of <<Name of the bidder>>.

We wish to inform you that we have read and understood the technical specification and total requirement of the above mentioned bid submitted by us on **DD.MM.YYYY**.

We hereby confirm that all our quoted items meet or exceed the requirement and are absolutely compliant with specifications mentioned in the bid document.

We also explicitly understand that all quoted items meet technical specification of the bid & that such technical specification overrides the brochures/standard literature if the same contradicts or is absent in brochures.

In case of breach of any tender terms and conditions or deviation from bid specification other than already specified as mentioned above, the decision of GIL Tender Committee for disqualification will be accepted by us.

The Information provided in our submitted bid is correct. In case any information provided by us are found to be false or incorrect, you have right to reject our bid at any stage including forfeiture of our EMD/PBG/cancel the award of contract. In this event, GIL reserves the right to take legal action on us.

Thanking you,

Dated this _____ day of _____ YYYY

Signature: _____

(In the Capacity of) : _____

Duly authorized to sign bid for and on behalf of

Note: This form should be signed by authorized signatory of bidder

PERFORMA OF UNDERTAKING

Undertaking of Authenticity for the proposed Solution

This has reference to Solution being quoted to you vide your tender no. HWT140818506 dated _____

We hereby undertake that the Solution quoted by us of in this bid will be able to communicate with the existing BISAG Setup for GIS based Application at BISAG as per the scope defined in the bid document.

If any additional Hardware / Module/ Software Licenses required for the integration with the existing setup of BISAG, then the necessary arrangement will be provided by us without any additional cost to BISAG, Government of Gujarat.

Authorized Signatory

Name:

Designation:

Note: The signing Authority should be no lower than Company Secretary.

Annexure A

Format of Earnest Money Deposit in the form of Bank Guarantee

Ref:

Bank Guarantee No.

Date:

To,

DGM (Technical)

Gujarat Informatics Limited

8th Floor, Block -1, Udyog Bhavan,

Sector - 11, Gandhinagar - 382010

Gujarat, India

Whereas ----- (here in after called "the Bidder") has submitted its bid dated ----- in response to the Tender no: HWT140818506 for Supply, Installation, Commissioning and Maintenance of Server, Storage & related Equipments for GIS based Application on behalf of Bhaskaracharya Institute for Space Applications and Geo-Informatics (BISAG), Gandhinagar KNOW ALL MEN by these presents that WE -----
----- having our registered office at ----- (hereinafter called "the Bank") are bound unto the Gujarat Informatics Limited in the sum of ----- for which payment well and truly to be made to Gujarat Informatics Limited, the Bank binds itself, its successors and assigns by these presents. Sealed with the Common Seal of the said Bank this -----day of ----- YYYY.

THE CONDITIONS of this obligation are:

1. The E.M.D. may be forfeited:

- a. if a Bidder withdraws its bid during the period of bid validity
- b. Does not accept the correction of errors made in the tender document;
- c. In case of a successful Bidder, if the Bidder fails:
 - (i) To sign the Contract as mentioned above within the time limit stipulated by purchaser or
 - (ii) To furnish performance bank guarantee as mentioned above or
 - (iii) If the bidder is found to be involved in fraudulent practices.
 - (iv) If the bidder fails to submit the copy of purchase order & acceptance thereof.
 - (v) If the successful bidder fails to submit the Performance Bank Guarantee & sign the Contract Form within prescribed time limit, the EMD of the successful bidder will be forfeited. GIL also reserves the right to blacklist such bidder from participating in future tenders if sufficient cause exists.

We undertake to pay to the GIL/Purchaser up to the above amount upon receipt of its first written demand, without GIL/ Purchaser having to substantiate its demand, provided that in its demand GIL/ Purchaser will specify that the amount claimed by it is due to it owing to the occurrence of any of the abovementioned conditions, specifying the occurred condition or conditions.

This guarantee will remain valid up to 9 months from the last date of bid submission. The Bank undertakes not to revoke this guarantee during its currency without previous consent of the OWNER/PURCHASER and further agrees that if this guarantee is extended for a period as mutually agreed between bidder & owner/purchaser, the guarantee shall be valid for a period so extended provided that a written request for such extension is received before the expiry of validity of guarantee.

The Bank shall not be released of its obligations under these presents by any exercise by the OWNER / PURCHAER of its liability with reference to the matters aforesaid or any of them or by reason or any other acts of omission or commission on the part of the OWNER/PURCHASER or any other indulgence shown by the OWNER/PURCHASER or by any other matter or things.

The Bank also agree that the OWNER/PUCHASER at its option shall be entitled to enforce this Guarantee against the Bank as a Principal Debtor, in the first instance without proceeding against the SELLER and not withstanding any security or other guarantee that the OWNER/PURCHASER may have in relation to the SELLER's liabilities.

Dated at _____ on this _____ day of _____ YYYY.

Signed and delivered by

For & on Behalf of

Name of the Bank & Branch &
Its official Address

Approved Bank: All Nationalized Bank including the public sector bank or Private Sector Banks or Commercial Banks or Co-Operative & Rural Banks (operating in India having branch at Ahmedabad/ Gandhinagar) as per the G.R. no. EMD/10/2018/18/DMO dated 16.04.2018 (http://www.gil.gujarat.gov.in/grs/DMO_2173_16_Apr_2018_714.pdf) issued by Finance Department or further instruction issued by Finance department time to time.

SECTION VIII

**Performa of Contract-cum-Equipment
Performance Bank Guarantee**
(To be stamped in accordance with Stamp Act)

Ref:

Bank Guarantee No.

Date:

To

Name & Address of the Purchaser/Indenter

Dear Sir,

In consideration of Name & Address of the Purchaser/Indenter, Government of Gujarat, Gandhinagar (hereinafter referred to as the OWNER/PURCHASER which expression shall unless repugnant to the context or meaning thereof include successors, administrators and assigns) having awarded to M/s having Principal Office at (Hereinafter referred to as the "SELLER" which expression shall unless repugnant to the context or meaning thereof include their respective successors, administrators, executors and assigns) the supply of _____ by issue of Purchase Order No..... Dated issued by <<GoG Department>> for and on behalf of the OWNER/PURCHASER and the same having been accepted by the SELLER resulting into CONTRACT for supplies of materials/equipments as mentioned in the said purchase order and the SELLER having agreed to provide a Contract Performance and Warranty Guarantee for faithful performance of the aforementioned contract and warranty quality to the OWNER/PURCHASER, _____ having Head Office at (hereinafter referred to as the 'Bank' which expressly shall, unless repugnant to the context or meaning thereof include successors, administrators, executors and assigns) do hereby guarantee to undertake to pay the sum of Rs. _____ (Rupees _____) to the OWNER/PURCHASER on demand at any time up to _____ without a reference to the SELLER. Any such demand made by the OWNER/PURCHASER on the Bank shall be conclusive and binding notwithstanding any difference between Tribunals, Arbitrator or any other authority.

The Bank undertakes not to revoke this guarantee during its currency without previous consent of the OWNER/PURCHASER and further agrees that the guarantee herein contained shall continue to be enforceable till the OWNER/PURCHASER discharges this guarantee. OWNER/PURCHASER shall have the fullest liberty without affecting in any way the liability of the Bank under this guarantee from time to time to extend the time for performance by the SELLER of the aforementioned CONTRACT. The OWNER/PURCHASER shall have the fullest liberty, without affecting this guarantee, to postpone from time to time the exercise of any powers vested in them or of any right which they might have against the SELLER, and to exercise the same at any time in any manner, and either to enforce to forebear to enforce any covenants contained or implied, in the aforementioned CONTRACT between the OWNER/PURCHASER and the SELLER or any other course of or remedy or security available to the OWNER/PURCHASER.

The Bank shall not be released of its obligations under these presents by any exercise by the OWNER/PURCHAER of its liability with reference to the matters aforesaid or any of them or by reason or any other acts of omission or commission on the part of the OWNER/PURCHASER or any other indulgence shown by the OWNER/PURCHASER or by any other matter or things.

The Bank also agree that the OWNER/PUCHASER at its option shall be entitled to enforce this Guarantee against the Bank as a Principal Debtor, in the first instance without proceeding against the SELLER and not withstanding any security or other guarantee that the OWNER/PURCHASER may have in relation to the Seller's liabilities.

Notwithstanding anything contained herein above our liability under this Guarantee is restricted to Rs. _____ (Rupees _____) and it shall remain in force up to and including _____ and shall be extended from time to time for such period as may be desired by the SELLER on whose behalf this guarantee has been given.

Dated at _____ on this _____ day of _____ YYYY.

Signed and delivered by

For & on Behalf of

Name of the Bank & Branch &
Its official Address

List of approved Banks

Approved Bank: All Nationalized Bank including the public sector bank or Private Sector Banks or Commercial Banks or Co-Operative & Rural Banks (operating in India having branch at Ahmedabad/ Gandhinagar) as per the G.R. no. EMD/10/2018/18/DMO dated 16.04.2018 (http://www.gil.gujarat.gov.in/grs/DMO_2173_16_Apr_2018_714.pdf) issued by Finance Department or further instruction issued by Finance department time to time.

CONTRACT FORM

THIS AGREEMENT made the _____ day of _____, YYYY ____ Between _____ (Name of purchaser) of _____ (Country of Purchaser) hereinafter "the Purchaser" of the one part and _____ (Name of Supplier) of _____ (City and Country of Supplier) hereinafter called "the Supplier" of the other part :

WHEREAS the Purchaser is desirous that certain Goods and ancillary services viz., _____ (Brief Description of Goods and Services) and has accepted a bid by the Supplier for the supply of those goods and services in the sum of _____ (Contract Price in Words and Figures) hereinafter called "the Contract Price in Words and Figures" hereinafter called "the Contract Price."

NOW THIS AGREEMENT WITNESSETH AS FOLLOWS:

- 1 In this Agreement words and expressions shall have the same meanings as are respectively assigned to them in the Conditions of Contract referred to.
- 2 The following documents shall be deemed to form and be read and construed as part of this Agreement, viz.:
 - 2.1 the Bid Form and the Price Schedule submitted by the Bidder;
 - 2.2 terms and conditions of the bid
 - 2.3 the Purchaser's Notification of Award
- 3 In consideration of the payments to be made by the Purchaser to the Supplier as hereinafter mentioned, the Supplier hereby covenants with the Purchaser to provide the goods and services and to remedy defects therein in conformity in all respects with the provisions of the Contract.
- 4 The Purchaser hereby covenants to pay the Supplier in consideration of the provision of the goods and services and the remedying of defects therein, the Contract Price or such other sum as may become payable under the provisions of the Contract at the times and in the manner prescribed by the Contract.
- 5 Particulars of the goods and services which shall be supplied / provided by the Supplier are as enlisted in the enclosed annexure:

TOTAL VALUE:

DELIVERY SCHEDULE:

IN WITNESS whereof the parties hereto have caused this Agreement to be executed in accordance with their respective laws the day and year first above written.

Signed, Sealed and Delivered by the

Said _____ (For the Purchaser)

In the presence of _____

Signed, Sealed and Delivered by the

Said _____ (For the Supplier)

In the presence of _____